

TGD1
Geared Machine with optional sheave brake

Complete Operation and Service Manual



Contents

Limited Liability, Warranty and Safety Precautions

1.0 Application

1.1 Overview	6
1.2 Codes & standards	6
1.3 Environmental Specifications	6
1.4 Machine Specifications	6

2.0 Machine Component Overview

2.1 Machine Assembly	8
2.2 Normal Brake Assembly	8
2.3 Emergency Brake Assembly	9

3.0 Safety Precautions

3.1 Terms in This Manual	10
3.2 General Safety	10
3.3 Electrical Safety	10
3.4 Electrical Hazards	10
3.5 Mainline Disconnect	10
3.6 Test Equipment Safety	11
3.7 When Power Is On	11
3.8 Product Safety Warnings	11

4.0 Arrival of the equipment

4.1 Receiving	12
4.2 Storage	12
4.3 Hoisting	12

5.0 Installation

5.1 Motor Connection	14
5.2 Brake Connection	14
5.3 Incremental Encoder Connection	15

6.0 Maintenance

6.1 Brake Stroke Check	16
6.2 Brake Lining Wear Check	16

6.3 Lubricating Check & oil Change	18
7.0 Adjustment	19
7.1 Brake Torque Adjustment	19
7.1.1 Normal Brake Torque Adjustment	19
7.1.2 Emergency Brake Torque Adjustment	21
7.2 Brake Stroke Adjustment	23
7.2.1 Normal Brake Stroke Adjustment	24
7.2.2 Emergency Brake Stroke Adjustment	25
7.3 Brake Synchronous Adjustment	29
8.0 Replacement	30
8.1 Encoder Replacement	30
8.1.1 Encoder Removal Instructions	30
8.1.2 Encoder Mounting Instructions	31
8.2 Brake Switch Replacement	31
8.2.1 Normal Brake Switch Replacement	31
8.2.1.1 Normal Brake Switch Removal Instructions	31
8.2.1.2 Normal Brake Switch Mounting Instructions	32
8.2.1.3 Normal Brake Switch Adjustment	32
8.2.2 Emergency Brake Switch Replacement	32
8.2.2.1 Emergency Brake Switch Removal Instructions	33
8.2.2.2 Emergency Brake Switch Mounting Instructions	33
8.2.2.3 Emergency Brake Switch Adjustment	33
8.3 Motor Replacement	34
8.3.1 Motor Removal Instructions	34
8.3.2 Motor Reassembly Instructions	35
8.4 Brake Replacement	35
8.4.1 Normal Brake Replacement	35
8.4.1.1 Normal Brake Removal Instructions	35
8.4.1.2 Normal Brake Mounting Instructions	36
8.4.2 Emergency Brake Replacement	37
8.4.2.1 Emergency Brake Removal Instructions	37
8.4.2.2 Emergency Brake Mounting Instructions	39

8.5 Brake Lining Replacement	42
8.5.1 Normal Brake Lining Replacement	42
8.5.1.1 Normal Brake Lining Removal Instructions	42
8.5.1.2 Normal Brake Lining Installation Instructions	43
8.5.2 Emergency Brake Lining Replacement	44
8.5.2.1 Emergency Brake Lining Removal Instructions	44
8.5.2.2 Emergency Brake Lining Installation Instructions	44
8.6 Sheave Replacement	47
8.6.1 Sheave Removal Instructions	47
8.6.2 Sheave Installation Instructions	49
8.7 Ring Gear Replacement	51
8.7.1 Ring Gear Replacement Instructions	51
8.7.1.1 Backlash Adjustment	54
8.8 Bearing Replacement	58
8.8.1 Output Shaft Bearing Replacement	58
8.8.2 Worm Gear Bearing Replacement	59
8.9 O-Ring & Seal Replacement	61
8.9.1 Replacement on the Output Shaft	61
8.9.1.1 If an oil Leak Happened at the Bearing Gland	61
8.9.1.2 If an Oil Leak Happened at the Spindle Through Cover	61
8.9.2 Replacement on the Worm Shaft	62
9.0 Manual Brake Release Instructions	63
9.1 Method of Application	63
10.0 Troubleshooting Chart	64
11.0 Traction Machine Assembly	65
12.0 Induction motors & encoders	69
13.0 Brake Assembly	70
13.1 Normal Brake Assembly	70
13.2 Emergency Brake Assembly	71
14.0 Mechanical Dimensions	73

IMPORTANT LIMITED LIABILITY AND WARRANTY NOTICE - PLEASE READ:
REVISED AND EFFECTIVE SEPTEMBER 1, 2014

- **Express Limited Warranty - What is Covered:**

Effective September 1, 2014, Torin Drive International, LLC ("TDI") expressly warrants that the machines it sells to you will be free from defects in material and workmanship for a period of 12 months from the date of delivery. This express limited warranty is in lieu of all other warranties or conditions, express or implied (statutory or otherwise), verbal or written.

- **Express Limited Warranty - What is Not Covered:**

This express limited warranty does not cover defects, failures, or conditions in the machines sold to you by TDI that are due to normal wear and tear; abuse; misuse; misapplication; improper installation; improper modification/adjustment/repair; inadequate maintenance; failure to follow the machine's use and safety instructions; or any other contributing factors unrelated to the machine's material and workmanship.

- **All Implied Warranties Disclaimed to the Fullest Extent Allowed by Applicable Law:**

TDI's express limited warranty is in lieu of all other warranties or conditions, express or implied (statutory or otherwise), verbal or written. To the fullest extent allowed by applicable law, TDI EXPLICITLY DISCLAIMS ALL IMPLIED WARRANTIES OR CONDITIONS, INCLUDING BUT NOT LIMITED TO THE IMPLIED WARRANTY OF FITNESS FOR A PARTICULAR PURPOSE AND THE IMPLIED WARRANTY OF MERCHANTABILITY.

- **TDI Disclaims All Consequential Damages Relating to Its Express Limited Warranty:**

With the exception of the express limited warranty described above, to the fullest extent allowed by applicable law, TDI disclaims, and shall not be liable for direct, indirect, proximate, incidental, economic, and/or consequential damages relating in any way to the installation, use, maintenance, and operation of the machines it sells to you. Specifically, TDI shall not be liable for property damage; loss of profits; labor costs; downtime; legal costs; or any other damages measurable in money that arise from or relate in any way to the installation, use, maintenance, and operation of the machines it sells to you. This disclaimer and exclusion of consequential damages shall apply even if the express warranty fails of its essential purpose.

TDI's liability shall be limited to the terms of this express limited warranty. TDI's Limitation of Liability also applies to any pre-sale consulting with you (including any preliminary technical data consultations or reports); any post-sale consulting with you; and any effort by TDI to repair the machines it sells to you pursuant to this express limited warranty. With the exception of the express limited warranty described above, you assume all risks associated with the machines that TDI sells to you. The implied warranty disclaimer and the liability disclaimer above are made to the fullest extent allowed by applicable law. In the event that some provision(s) of the above implied warranty disclaimer and/or the liability disclaimer are not permitted under applicable law, then all other provisions shall remain in full force and effect to the fullest extent permitted under applicable law.

- **No Other Express or Implied Warranty Applies:**

The express limited warranty described above is the sole and exclusive warranty, express or implied (statutory or otherwise), for the machines that TDI sells to you. No employee, agent, or representative of TDI is authorized to alter, modify, expand, or reduce the terms of TDI's express limited warranty or to make any other warranty on behalf of TDI.

- **Express Limited Warranty - How to Redeem:**

To obtain the benefit of TDI's express limited warranty, please contact Warranty Claim Department, TDI International, 7598 A E Beaty Drive, Suite 102, Bartlett, TN 38133 as soon as possible after a defect in the machine's material or workmanship has been discovered. Please note: you must contact TDI concerning a machine covered by this express limited warranty before you attempt any repair work. Any unauthorized disassembly, repair, or reassembling performed by you will void TDI's responsibilities under this express limited warranty.

- **Express Limited Warranty - What TDI Will Do:**

Machines that are covered by this express limited warranty will be repaired or replaced, at TDI's option, during the warranty period. TDI will cover the expenses relating to the repair or replacement of its machines under this express limited warranty. However, TDI shall not be liable for direct, indirect, proximate, incidental, economic, and/or consequential damages relating in any way to efforts by TDI to repair or replace the machines it sells to you pursuant to this express limited warranty. Specifically, TDI shall not be liable for property damage; loss of profits; labor costs; downtime; legal costs; or any other damages measurable in money that arise from or relate in any way to TDI's efforts to repair or replace the machines it sells to you pursuant to this express limited warranty. If, after two (2) attempts at repair or replacement during the warranty period, the machine defect in material or workmanship persists, then you may elect to receive a refund of your original purchase price for the machine.

(Revised Full/PDF Doc Version of Express Limited Warranty)

1.0 Application

1.1 Overview

The TGD1 Machine is a geared machine designed for elevators. Its worm and gear configuration allows speeds up to 400 fpm (maximum), and an elevator capacity of up to 2500 lbs. 1:1, and 5000 lbs. 2:1 maximum.

The TGD1 machine uses drum brake as normal brake and optional emergency sheave brake.

1.2 Codes and Standards

These machines are designed to comply with ASME A17.1 code. The motors are designed with insulation class F minimum and have been approved and labeled by CSA.

1.3 Environmental Specifications

Operating ambient temperature: 0°C to 40°C (32°F to 104°F)

Storage temperature: 0°C to 60°C (32°F to 140°F)

Humidity: relative humidity of 10% to 95% non-condensing

Altitude: Up to 1000m above sea level without de-rating

1.4 Machine Specifications

A17.1 compliance

CSA B44.1/ASME A17.5 Certification

CSA file No. 243553

Induction motors: 208 OR 480V/60Hz/4-poles/3-phase

Brake coils: 110VDC / 2A OR 220vdc / 1A

Optional sheave brake coils: 110VDC / 2.75A

Maximum full load mass: 16500 lbs.

Demountable bronze gear

Sheave diameter: 25.6 inches

Up to 6 x 0.500 in. or 5 x 0.625 in. Ropes

Designed for 40% elevator duty cycle

Incremental encoder: 2048 pulse per revolution

Estimated weight: 1900 lbs.

Lubricating oil: 13.5L (3.5 gal)

Recommended oil is Shell Omala 460 or equivalent elevator gear oil.



Normal Brake Model: DZE-12E
 Pick/Hold Voltage: 110/60 VDC
 Pick/Hold Current: 2.00/1.18 A
 Resistance: 55 Ohms

Emergency brake model: DZE-20E
 Pick/Hold Voltage: 110/60 VDC
 Pick/Hold Current: 2.75/1.5 A
 Resistance: 40 Ohms

Table 1 Machine Duty Table

Model Number	Motor Rating	Elevator Duty	Gear Ratio	Application Motor RPM	Rated Motor FLA	CWT (%)	Sheave Side	Power Source (VAC)
TGD1-2510-HV-R	10 HP	2100-2500 lbs. / 100 fpm	61:1	910	14	40	Right	480
TGD1-2510-HV-L					Left			
TGD1-2510-LV-R					32		Right	208
TGD1-2510-LV-L					Left			
TGD1-2520-HV-R	20 HP	2100-2500 lbs. / 200 fpm	50:1	1492	23	40	Right	480
TGD1-2520-HV-L					Left			
TGD1-2520-LV-R					53		Right	208
TGD1-2520-LV-L					Left			
TGD1-2535-HV-R	25 HP	2100-2500 lbs. / 350 fpm	61:2	1593	28	40	Right	480
TGD1-2535-HV-L					Left			
TGD1-2535-LV-R					64		Right	208
TGD1-2535-LV-L					Left			
TGD1-2540-HV-R	30 HP	2100-2500 lbs. / 400 fpm	55:2	1641	33	40	Right	480
TGD1-2540-HV-L					Left			
TGD1-2540-LV-R					75		Right	208
TGD1-2540-LV-L					Left			

2.0 Machine Component Overview

2.1 Machine Assembly

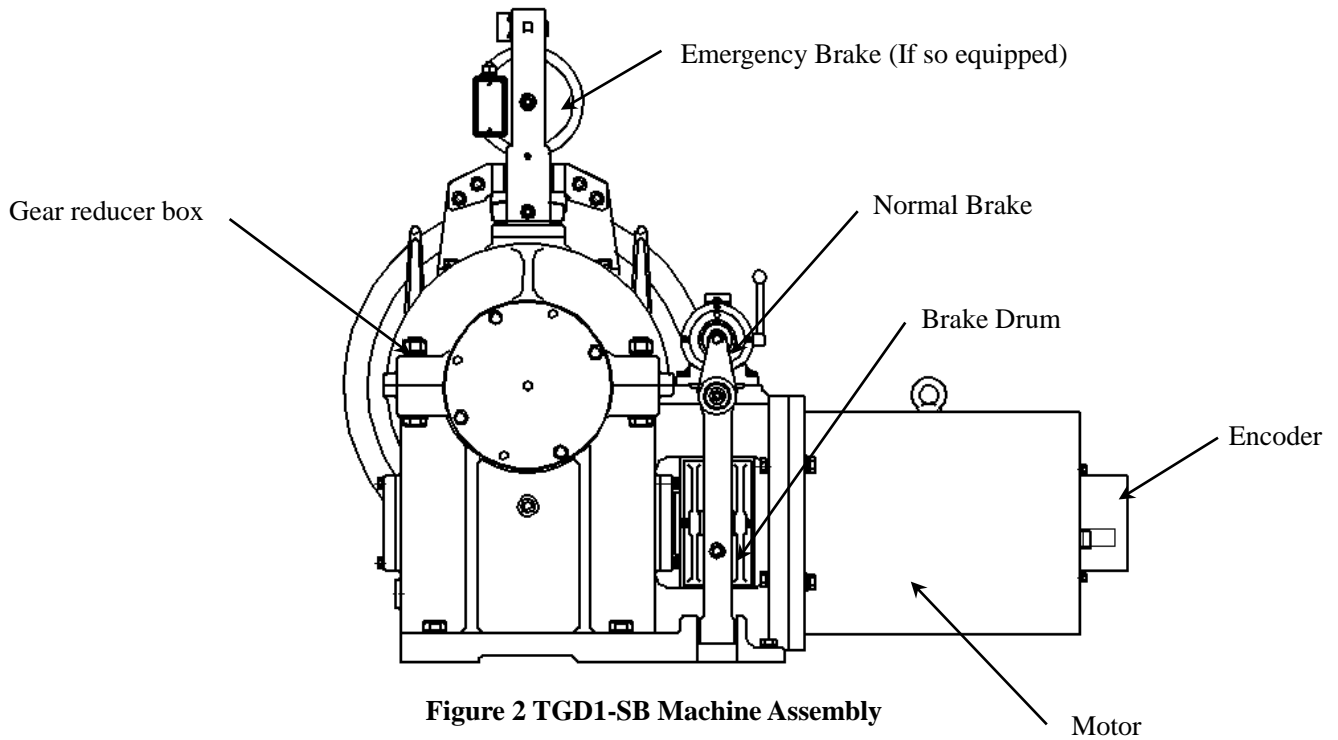

Figure 2 TGD1-SB Machine Assembly

2.2 Normal Brake Assembly

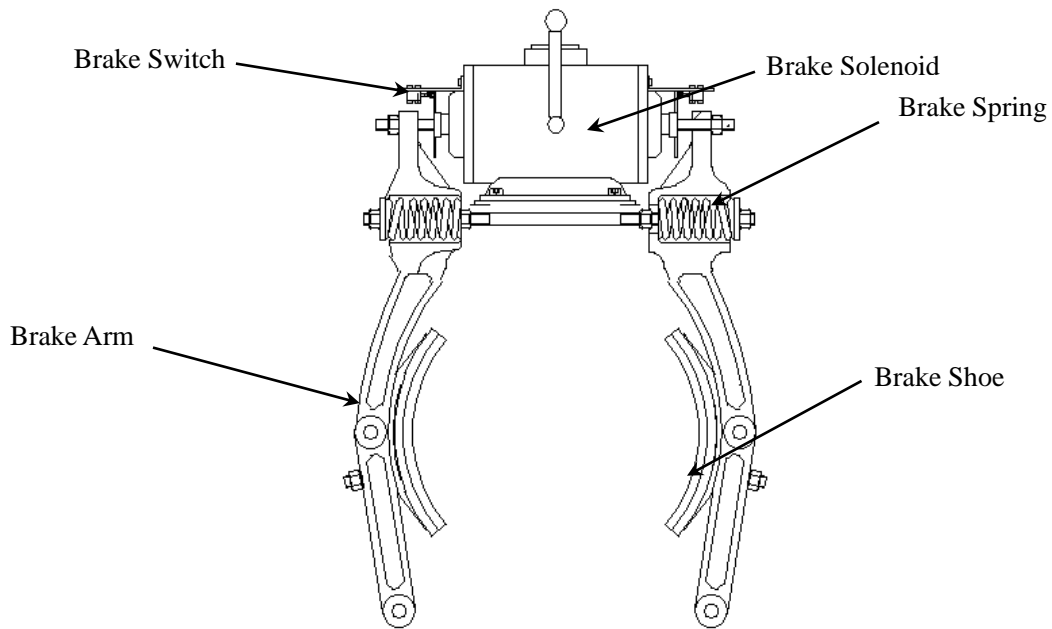

Figure 3 Normal Brake Assembly

2.3 Emergency Brake Assembly

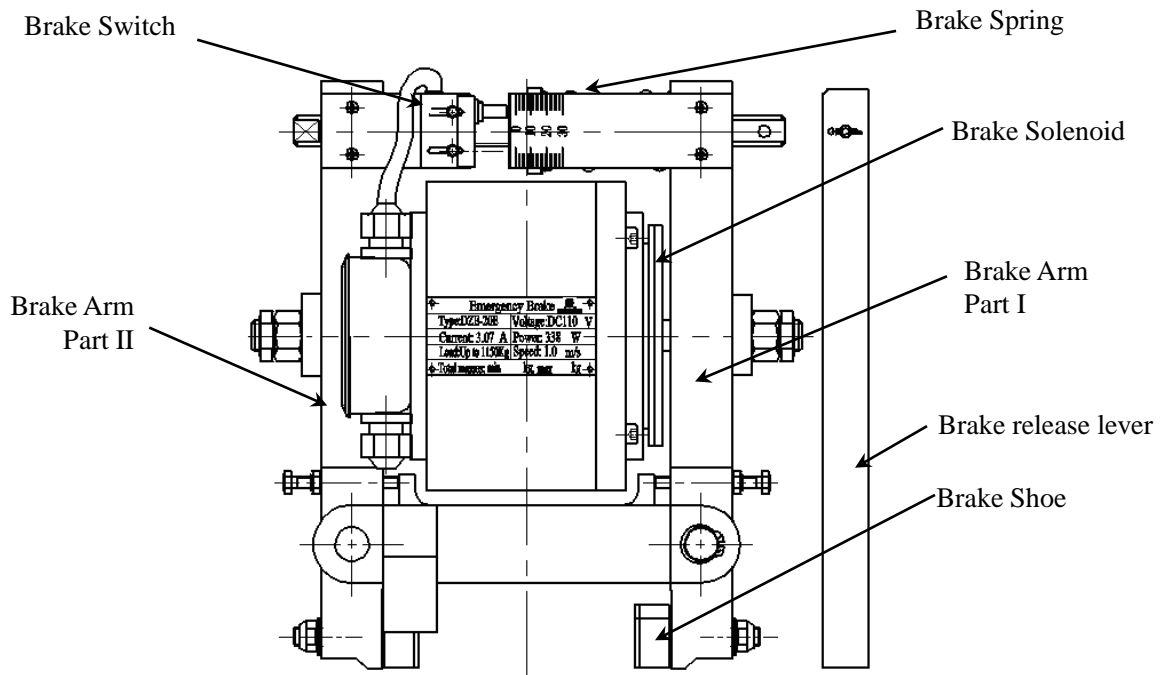

Figure 4 Emergency Brake Assembly

3.0 Safety Precautions

Important! Read this page BEFORE any work is performed on Elevator Equipment.

The procedures contained in this manual are intended for the use of qualified elevator personnel. In the interest of your personal safety and the safety of others, do NOT attempt ANY procedure that you are NOT qualified to perform. Always follow your company and OSHA required safety procedures and policies when performing ANY tasks.

All procedures must be done in accordance with the applicable rules in the latest edition of the National Electrical Code; the latest edition of ASME A17.1; and any governing local codes.

3.1 Terms in This Manual



CAUTION statements identify conditions that could result in damage to the equipment or other property if improper procedures are followed.



WARNING statements identify conditions that could result in personal injury if improper procedures are followed.

3.2 General Safety

Specific warnings and cautions are found where they apply, and DO NOT appear in this summary.

3.3 Electrical Safety

All wiring must be in accordance with the National Electrical Code, and must be consistent with all state and local codes.

3.4 Electrical Hazards

Electric shocks can cause personal injury or loss of life. Circuit breakers, switches and fuses may **NOT** disconnect all power to the equipment. Always refer to the wiring diagrams. Whether the AC supply is grounded or not, high voltage will be present at many points.

3.5 Mainline Disconnect

Unless otherwise suggested, always turn OFF, Lock and Tag out the mainline disconnect to remove power from the equipment.

3.6 Test Equipment Safety

Always refer to manufacturers' instruction book for proper test equipment operation and adjustments.

Buzzer type continuity testers can damage electronic components. Connection of devices such as voltmeters on certain low level analog circuits may degrade electronic system performance. Always use a voltmeter with a minimum impedance of 1M Ohm/Volt. A digital voltmeter is recommended.

3.7 When Power Is On

Dangerous voltages exist at several points in some products. To avoid personal injury, do **NOT** touch exposed electrical connections or components while power is **ON**.

3.8 Product Specific Warnings



The TGD1 Machine **MUST** be balanced during hoisting. See Hoisting Methods in the Installation section for proper lifting procedures.



Hang the elevator car before working on the machine. Failure to do so may result in severe injury and equipment damage.

4.0 Arrival of the Equipment

4.1 Receiving

Upon arrival of the machine, make a visual check for any external damage immediately upon their arrival on site. If any damage is found that occurred during transit, make a notice of claim in the presence of the forwarder. If necessary, do not put these machines into operation.

4.2 Storage

During storage in a warehouse or on the elevator job site, precautions should be taken to protect the machine from dust, dirt, moisture, and extreme temperatures.

4.3 Hoisting

TGD1 machines can be lifted by using a combination of hooks, chains & slings designed to safely carry the weight of the machine. See figure 1.1.

Note: Tighten all eye bolts before hoisting machine, motor or gear box, and always use properly rated hoisting equipment with certified rigging personal on-site. Inspect all equipment/tools being used before every task.

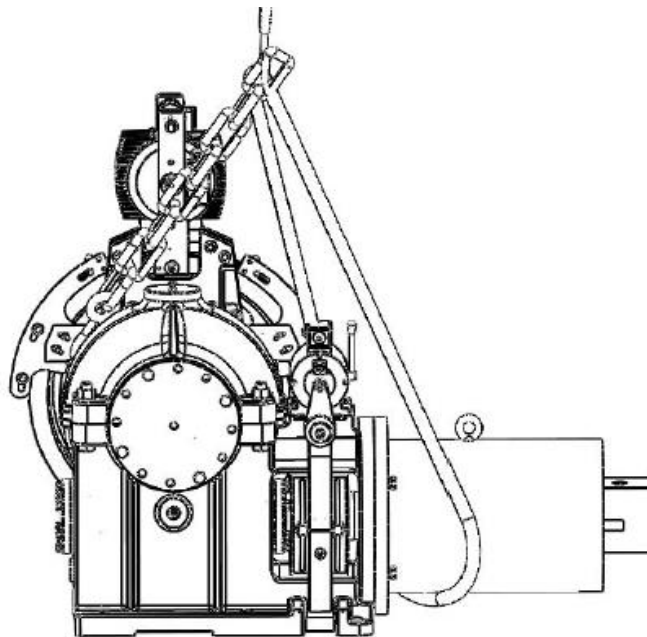

Figure 1.1 TGD1 Machine Recommended Hoisting Method

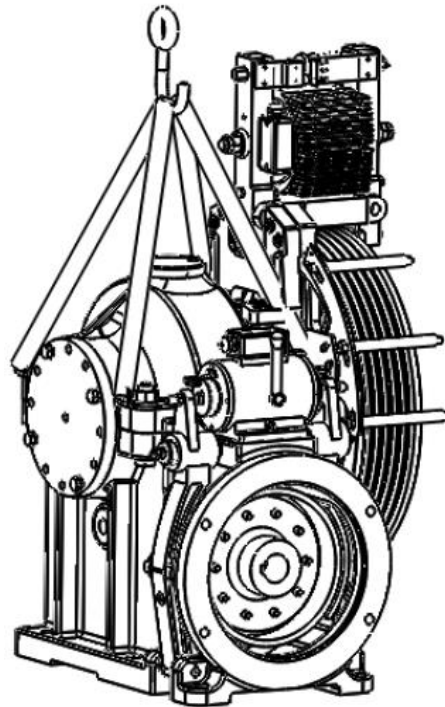

Figure 1.2 TGD1 Gear Box Recommended Hoisting Method

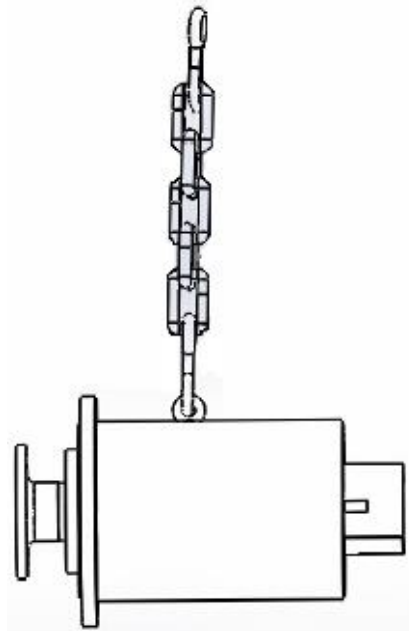

Figure 1.3 TGD1 Motor Recommended Hoisting Method

5.0 Installation

5.1 Motor Connection

Use the job wiring diagrams with the motor configuration information to connect the motor to the controller.

Inverter drive output reactor: it is strongly recommended that a reactor to be installed between the inverter and motor to filter out high transient peak voltages that may damage the motor windings.



Before operating the machine, refer to the appropriate Product Manual and verify that the drive parameters for the job are set correctly.

Motor Connection

Connect the motor cable (U, V, W, and grounding) to three phase AC drive then to frequency inverter output terminal, and check the short-circuiting between the windings and the ground before connection.

5.2 Brake Connection

The power terminal of brake is BK+ (positive pole), BK-(negative pole).

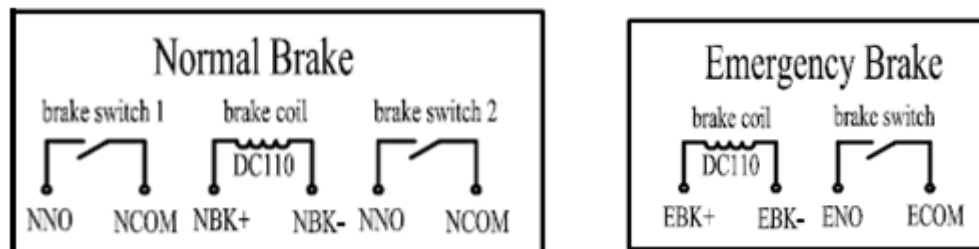

Figure 5 Normal & Emergency Brake Wiring

There are two micro switches installed in the normal brake and one micro switch installed in the emergency brake, which are used to feed back the action of the brake. User can connect it according to your control system requests.

5.3 Incremental Encoder Connection

These machines are supplied with HS35 Incremental Optical Encoder. The incremental resolution is 2048 pulses per revolution. The field personnel can connect the encoder to the inverter using special shielded-twisted-pair cable by following the figure below for proper encoder signals: A and /A, B and /B, +V and GND (+V and GND is the encoder power supply that can be from 5VDC to 28VDC. Torin Drive recommends using 5VDC to extend the life of the encoder.).

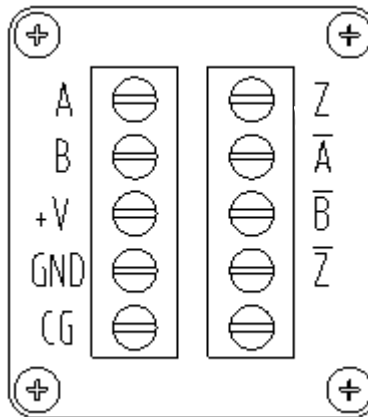

Figure 6 Encoder Terminal Block

Note: machine is ready to run.

6.0 Maintenance



Only qualified personnel are allowed to perform any maintenance work. The person who performs the maintenance work must be very careful because some work must be performed when the machine is running. Always make sure the elevator is safely under control before attempting any of the following procedures.

6.1 Brake Stroke Check



Please pay attention to the value of brake stroke during the course of routine maintenance. If the brake stroke is too short, the power of the solenoid cannot push the brake arm to obtain enough gap, which will result in a disabled brake. Generally, the brake stroke has been adjusted in the factory and does not need to be adjusted in the field.

Suggest check cycle

- 3 months after initial install
- 6 months after initial install
- Annually for the remaining life of the product

Benchmark Criteria

The gap which is the bottom of the **Normal Brake Shoe** and the **drum** should be 0.1~0.5mm (0.004"~0.02").

The gap which is at the bottom of the **Emergency Brake Shoe** and the **sheave** should be 0.05~0.1mm (0.002"~0.004").

6.2 Brake Lining Wear Check



If the brake lining wears too much, the brake will be disabled.

Suggest check cycle

- Annually after initial install

Benchmark Criteria

New **Normal** brake lining thickness is 8mm.

The Normal brake lining wear must be $<2\text{mm}$ (0.079"). Use steel ruler to measure the thickness of the brake shoe, the thickness must be $>6\text{mm}$ (0.236"). Otherwise replace the brake lining or replace the whole brake assembly. See Figure 20.

New **Emergency** brake lining thickness is 2mm.

The Emergency brake lining wear must be $<2\text{mm}$ (0.079"). Use steel ruler to measure the thickness of the brake shoe, the thickness must be $>20\text{mm}$ (0.79"). Otherwise replace the brake shoe. See Figure 21.

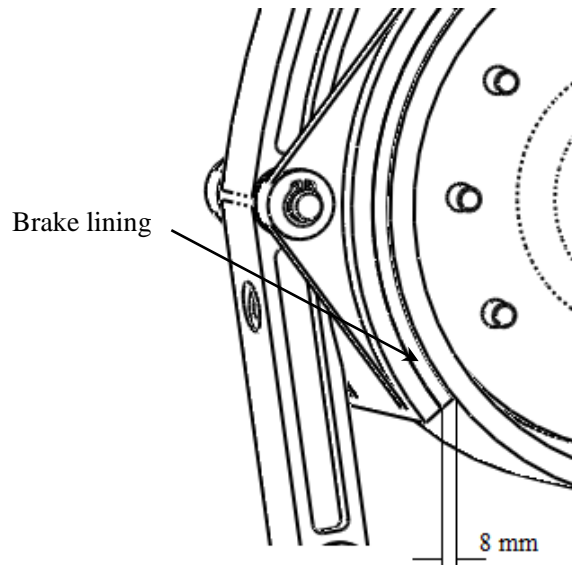

Figure 20 Normal brake lining

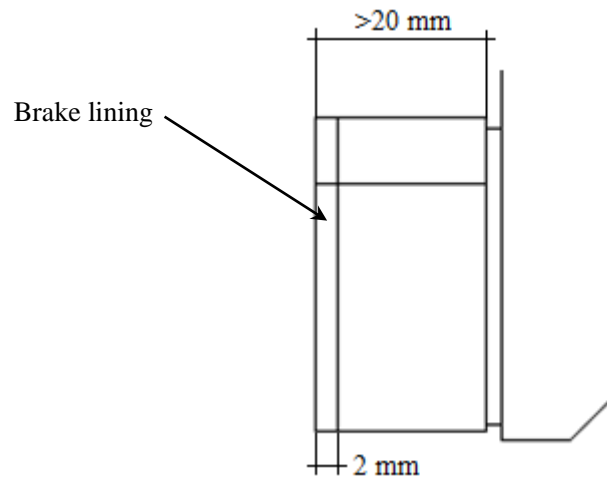

Figure 21 Emergency brake lining

6.3 Lubricating Check & Oil change

The oil type we recommend is Shell Omala 460 or equivalent elevator gear oil.



Whether the geared oil needs to be changed depends on the cleanliness and ageing degree. Check the oil color, smell and cleanliness degree and confirm whether oil needs to be changed. If oil turns black and smells foul, it should be changed. Use filter paper to check hot oil and watch for metal shavings to confirm whether oil needs changing. The oil volume of the TGD1 machine is 13.5L (3.5 gal). The oil level should be at scale mark (red dot). If it's too little, the lubrication will be not enough and if it's too much, the oil can leak out. If the machine is stored for more than 1 year, the oil should be changed before use.

Suggest check cycle

Using conventional mineral oil, the first time oil change should be done after the new machine runs **400 hours**. After that, depending on the machine running condition, change conventional oil each 2000-3000 hours (at most 12-18 months).

Note: Do not use synthetic oil!

For oil change it is not necessary to hang the car and remove the ropes.

Required Tools & Materials:

Open end Wrench: 16mm & 22mm

Funnel & Oil pan

Oil change procedure

1. Remove elevator from service and verify the elevator is under your control.
2. Take off top cover with 16mm wrench for air flow.
3. Place funnel and oil pan right next to the oil drain.
4. Remove oil plug, drain the old oil away.
5. When the oil has ceased running out of the geared box, hand tighten oil plug to make sure you're not cross-threading it, tighten the rest of the way with your 22mm wrench.
6. Pour in 13.5 L (3.5gal) conventional oil into the gear box top cover.
7. Run the car floor to floor for 10 minutes and check the machine running situation. Also check the gear box for any signs of heat or smoke, while verifying the proper disbursement of oil over the ring gear.

7.0 Adjustments

7.1 Brake Torque Adjustment



Generally, the brake torque has been adjusted in the factory and does not need to be re-adjusted any more. Normal Brake torque adjustment may be required if the brake fails the 125% load test. Proper brake operations with regard to loading **MUST** be verified before anyone is allowed to ride on the platform.

Preparation

1. Verify that any required Compensation Chains or Rope Assemblies have been installed.
2. On construction jobs, verify that hoist way barricades are in place to prevent unauthorized access.

7.1.1 Normal Brake Torque Adjustment

Required Tools & Materials:

Open end wrench: 18mm

Torque wrench

Adjustment wrench

12 point 22 mm socket

Hex wrench: 6mm

Adjustment Procedure Steps

1. Check the length of the spring's decrement, which is showed on the surveyor's rod. The surveyor's rod should show the following compress distance length See Table 2, otherwise the length must be readjusted.

- Park the counterweight on the buffers & remove the elevator from service.

Table 2 Normal Brake Spring Length Decrement

Motor Power	Compress distance
10Hp	5-7 mm
20Hp	12-14 mm
25Hp	12-14 mm
30Hp	12-14 mm

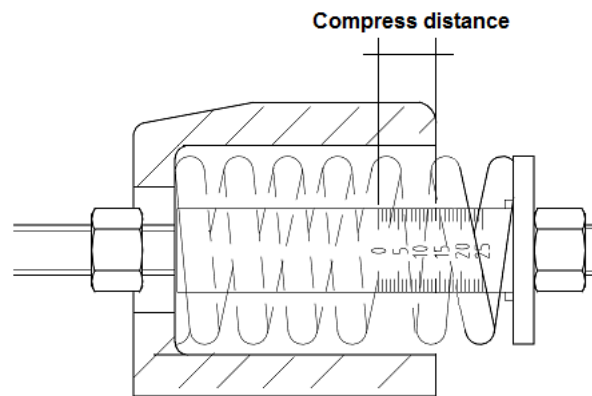

Figure 7 Normal Brake Spring Length Decrement

- Loosen the Spring Adjustment Locknut counterclockwise with an open end wrench 18mm, then adjust the Spring Adjustment nut slowly to ensure the decrement length is in range.

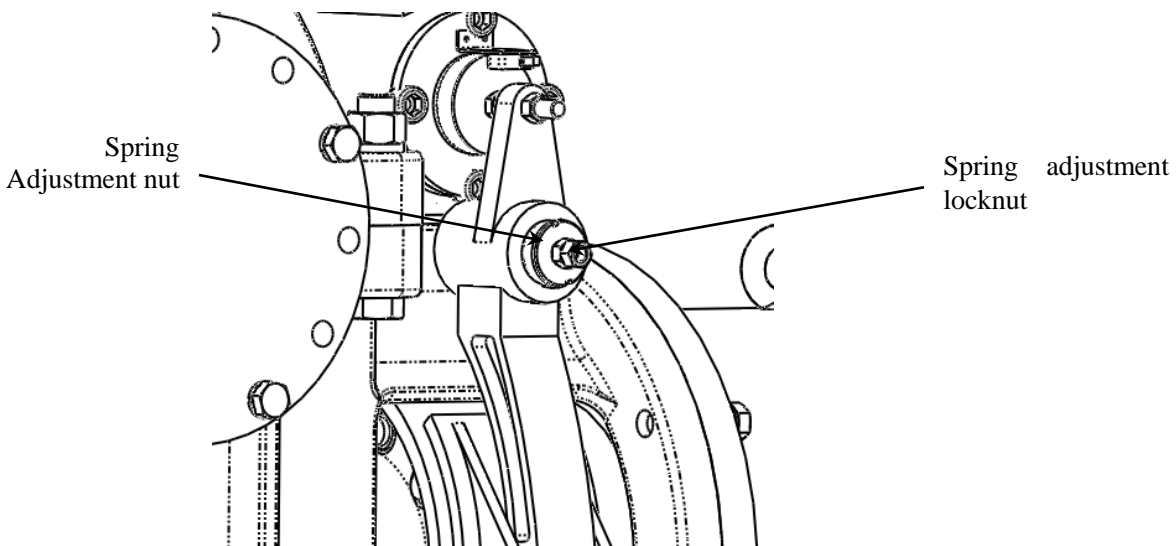
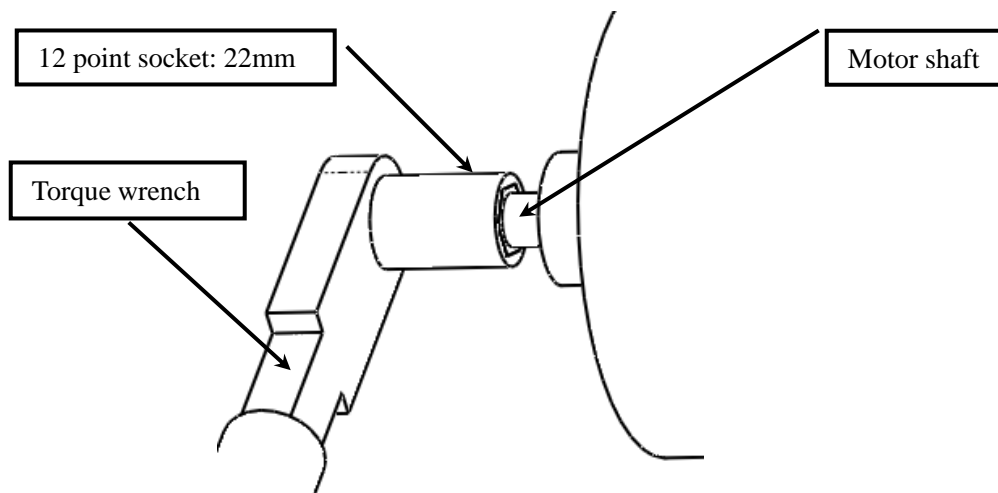

Figure 8 Brake Spring Adjustment

4. If the compress distance is too big, loosen the spring adjustment nut counterclockwise to reduce it. If the compress distance is too small, tighten the spring adjustment nut clockwise to increase the length.
5. Re-measure and confirm that the dimension is correct and then tighten spring adjustment locknut.
6. Also measure the brake torque with torque wrench. First of all, remove the encoder cover from the motor shaft. With a 12 point, 22mm socket and torque wrench on the end of the motor shaft, measure the torque, making sure that the emergency brake is open. The torque should match the value in Table 3. For information regarding how to remove the encoder cover, please refer to this manual, Section 8.1 Encoder Replacement.

Table 3 Normal Brake Torque

Motor Power	B
10Hp	$\geq 120\text{Nm}$ (88 ft-lb)
20Hp~30HP	$\geq 245\text{Nm}$ (181 ft-lb)

**Figure 9 Normal Brake Torque Test**

7.1.2 Emergency Brake Torque Adjustment

Required Tools & Materials:

Open end wrench: 30mm (2 piece)

Torque wrench

12 point 22mm socket

Hex wrench: 6mm

Adjustment Procedure Steps

1. Check the length of the spring's decrement, which is showed on the surveyor's rod. The surveyor's rod should show 16-18 mm, otherwise the length must be readjusted.

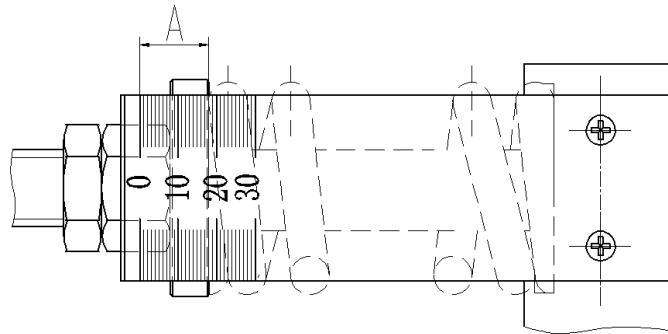

Figure 10 Emergency Brake Spring Length Decrement

2. Park the counterweight on the buffers & remove the elevator from service.
3. Loosen the Spring Adjustment Thin Locknut by 30mm open end wrench, then adjust the Spring Adjustment nut slowly to ensure the decrement length is in range.

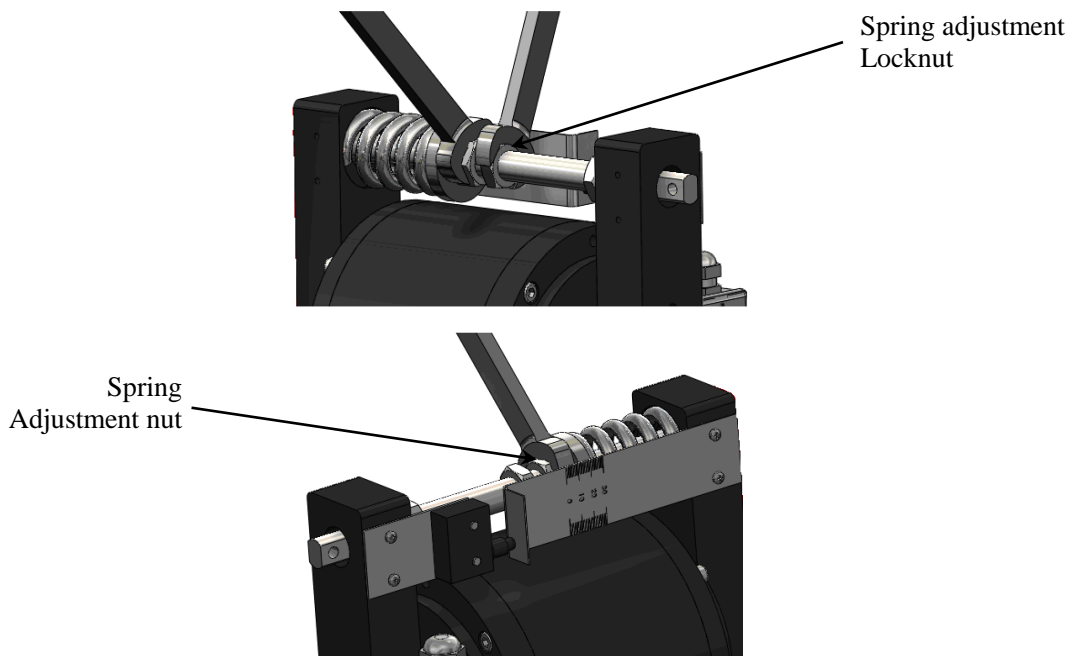

Figure 11 Emergency Brake Spring Adjustment

4. If the "A" dimension is too big, loosen the spring adjustment washer counter clockwise to reduce it. If the "A" dimension is too small, tighten the spring adjustment washer clockwise to increase the dimension.
5. Re-measure and confirm that the dimension is correct and then tighten spring adjustment thin locknut.

6. Also measure the brake torque by torque wrench. First of all, remove the encoder cover from the motor shaft, put a 12 point socket: 22mm into the motor shaft, install the torque wrench on the bolt to measure the torque, make sure that the normal brake is open and that the torque on torque wrench matches the following value [B]. See Table 4. For information regarding how to remove the encoder cover, please refer to this manual, Section 8.1 Encoder Replacement.

Table 4 Emergency Brake Torque

Rated Load	Speed	B
2500lbs	0.5m/s (100 FPM)	$\geq 100\text{Nm}$ (73 ft-lb)
2500lbs	1.0m/s (200 FPM)	$\geq 119\text{Nm}$ (88 ft-lb)
2500lbs	1.78m/s (350 FPM)	$\geq 156\text{Nm}$ (115 ft-lb)
2500lbs	2.03m/s (400 FPM)	$\geq 186\text{Nm}$ (137 ft-lb)

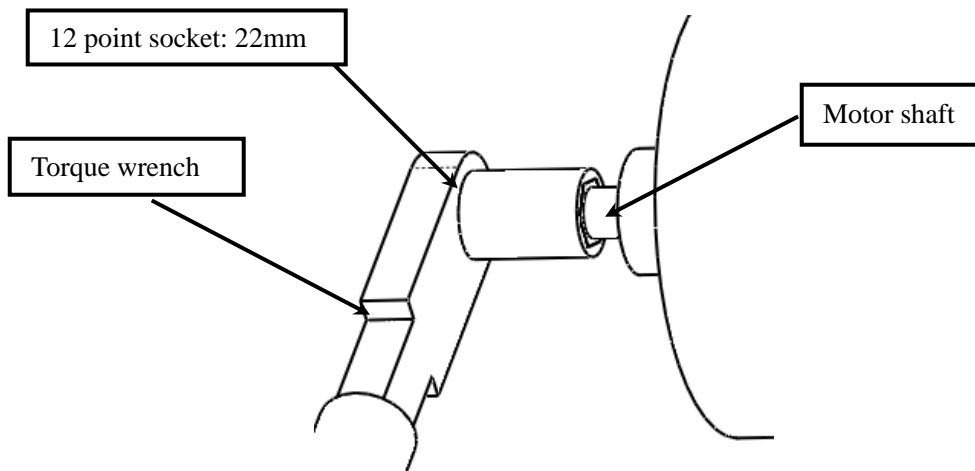
**Figure 12 Emergency Brake Torque Test**

7.2 Brake Stroke Adjustment



Generally, the brake stroke has been adjusted in the factory and does not need to be re-adjusted any more. Proper brake operations with regard to loading **MUST** be verified before anyone is allowed to ride on the platform.

Preparation

1. Verify that any required Compensation Chains or Rope Assemblies have been installed.
2. On construction jobs, verify that hoist way barricades are in place to prevent unauthorized access.

7.2.1 Normal Brake Stroke Adjustment

Required Tools & Materials:

Open End Wrench: 18mm

Hex wrench: 6mm

Feeler gauges

Adjustment Procedure Steps

If the brake stroke is too small, the brake drum and brake lining will rub, and the machine will make abnormal noise when it runs.

1. Loosen the Stroke adjustment locknut with 18 mm open end wrench, verify that the Hit Cap and the Stroke Adjustment Bolt just make contact when the brake's power is on, and screw the Stroke Adjustment Bolt with an 6mm hex wrench into the direction of the brake solenoid to 1.6~2.0mm (0.063"~0.079").

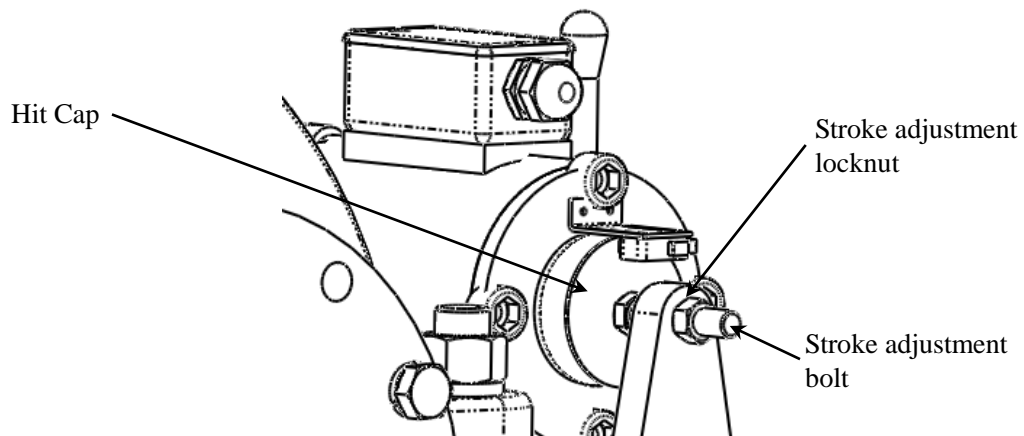

Figure 13 Normal Brake Stroke Adjustment

2. Measure the gap at the bottom of the Brake Shoe and the drum, verify it is 0.1-0.5 mm (0.004”~0.02”) with feeler gauges, and make sure the gap is about uniform from top to bottom. If the gap on the top is too big, loosen locknut with open end wrench 18 mm and tighten the bolt clockwise with hex wrench 6mm to reduce it. If the gap is too small, loosen the bolt counter-clockwise to increase the gap.

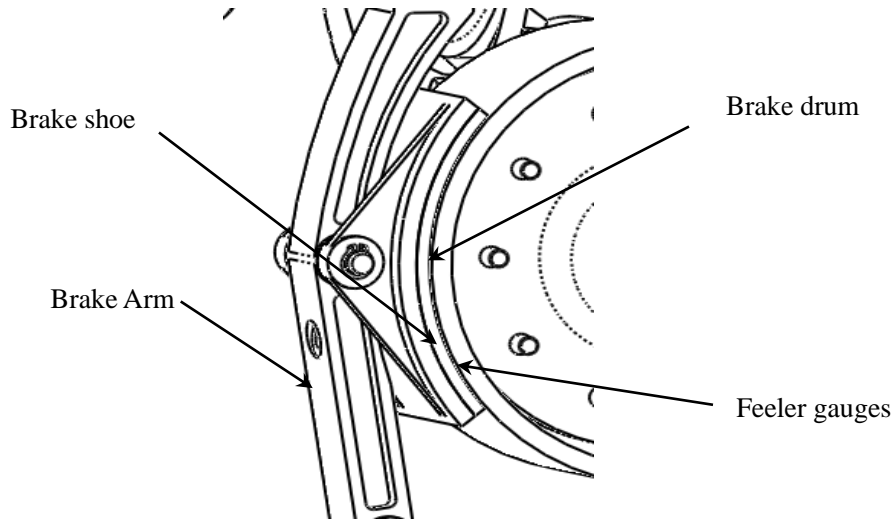

Figure 14 Normal Brake gap

7.2.2 Emergency Brake Stroke Adjustment

Required Tools & Materials:

Open End wrench: 7mm, 13mm, (2) 30mm

Phillips Screwdriver

Dial indicator

Feeler gauge

Rubber hammer

Torque Wrench (60Nm,) (45 ft-lb)

Adjustment Procedure Steps

1. Measure the gap between the side of the drive sheave and emergency brake lining, with the feeler gauge 0.05~0.1mm (0.002”~0.004”) when the brake is open. See Figure 15. Use the 0.05 mm (0.002”) feeler gauge as a “go gauge”, and the 0.1 mm (0.004”) as a “no go gauge”.

Note: Feeler gauge should be able to be inserted to 1 inch depth.

2. If the gap is too big loosen (1/6th of a turn at a time) the thin locknut M20 and nut M20 with a 30mm open end wrench counter-clockwise to reduce it. See Figure 16. Otherwise, tighten (1/6th of a turn at a time) the nut M20 clockwise to increase it.

Note: Make sure the Brake holding voltage <70% Brake rated voltage when adjusting the thin nut M20 and nut M20; Tighten the thin nut M20 after the adjustment to prevent the reading of dial indicators changing.

3. Attach two (2) dial indicators to the side of the drive sheave with the gauge head touching brake arm part I on one side and brake arm part II on the other side. See Figure 16. Check that the reading of the two dial indicators $\leq 0.25\text{mm}$ (0.01”), when the state of brake changes from open to closed.

Note: The dial indicators must be attached to the sheave as shown in Figure 16.

4. Make sure the reading of both sides is approximately the same. If one side is reading less loosen locknut’s M8 on both sides, then tighten the bolt M8 on the opposite side until the reading is even. Repeat step 3.

Note: If necessary the adjustment must be done on both sides.

5. Tighten the locknut M8 after the adjustment is synchronized.
6. Measure the distance between the center hole of Stud and Brake arm part I (17mm~18mm). See Figure 17.
7. If the distance is too small, write down the two (2) thin nut's distances (L); loosen the thin locknut’s M20 and nut M20 with a 30mm open end wrench to free the spring. See Figure 17
8. Tighten the other side nut M20 and thin locknut M20 with a 30mm open end wrench to compress spring.
9. If the gap is big use opposite method.

Note: The two (2) thin locknut's distances (L) should be the same as measured in Step 7 after adjusting.

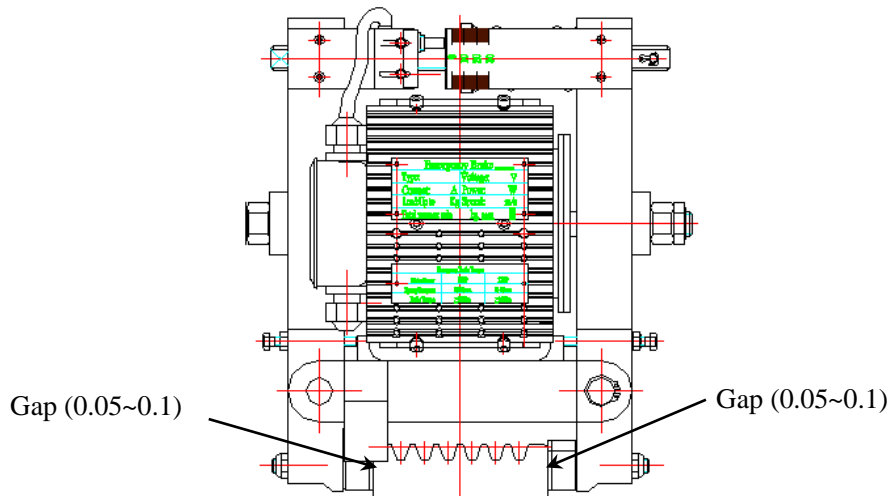

Figure 15

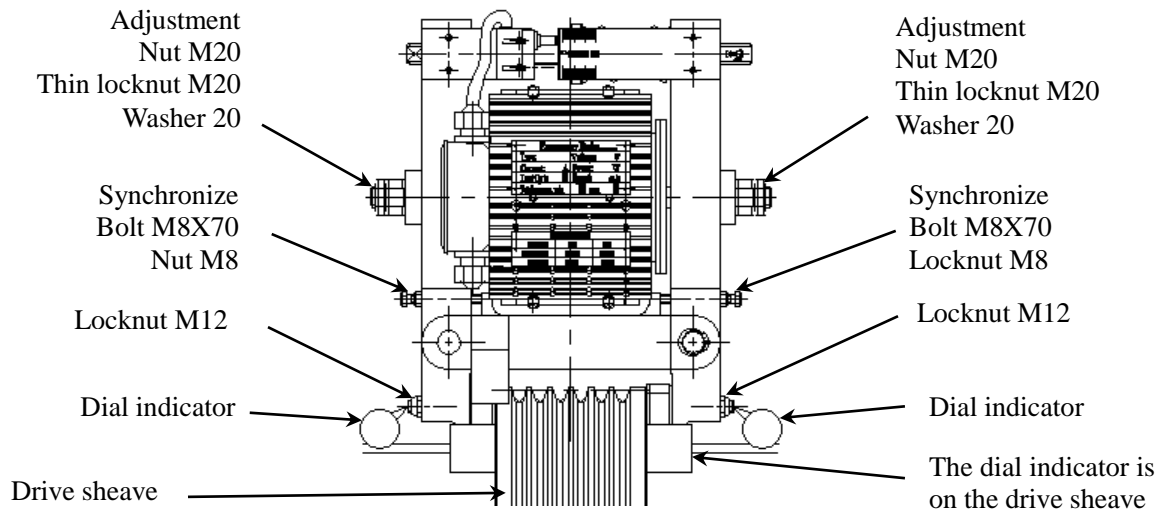

Figure 16

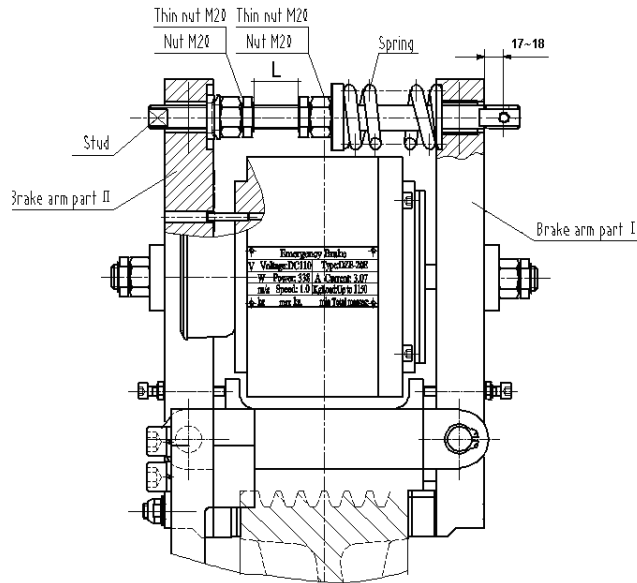

Figure 17

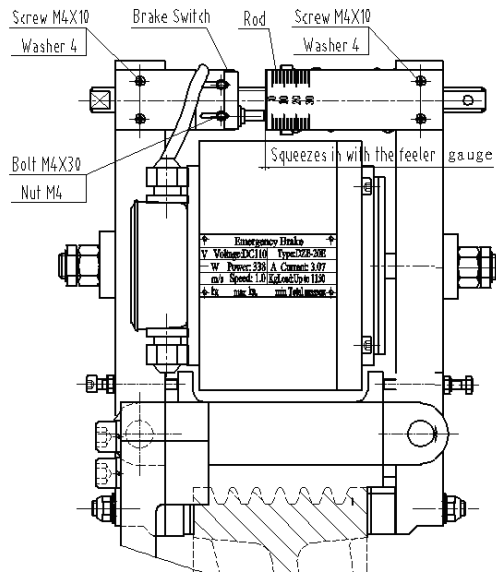

Figure 18

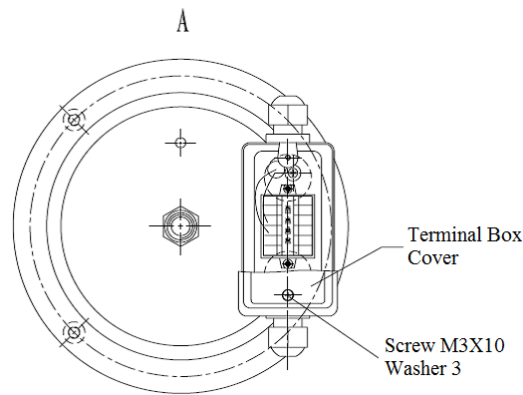

Figure 19

7.3 Brake Synchronous Adjustment



This step should be done when the brake torque meets the specified value [B] See Table 3).

Required Tools & Materials:

Open End Wrench: 18mm

Adjustment Procedure Steps for Normal Brake

1. If a Brake Arm opens slower than the other arm, loosen the Synchronization locknut and bolt of slower arm or tighten the faster arm synchronization bolt after loosening its locknut, until both arms opens and closes at the same time.
2. Once both arms open and close at the same time, then tighten the locknuts.
3. After adjusting, verify the brake torque according to **Section 6.1.1 Normal Brake Torque Adjustment**.

Adjustment Procedure Steps for Emergency Brake

4. If a Brake Arm opens slower than the other arm, loosen the Synchronization locknut M8 and the bolt of slower arm, or tighten the faster arm synchronization bolt M8 after loosening its locknut M8, until both arms open and close at the same time.
5. Once both arms open and close at the same time, then tighten the locknuts M8.
6. After adjusting, verify the brake torque according to **Section 6.1.2 Emergency Brake Torque Adjustment**.

8.0 Replacement



The user who does the replacement must make sure that the machine is powered off and the elevator is secure and will not be moved unexpectedly. Only qualified personnel are allowed to perform the replacement work.



Please refer to the troubleshooting procedure first and make sure that the component is actually bad before performing this replacement procedure.

8.1 Encoder Replacement

Required Tools & Materials:

Encoder

Small Flathead screwdriver

Hex wrench: 3mm, 4mm, 6mm, 8mm

Clean cloth

8.1.1 Encoder removal instructions

1. Remove the encoder cover using a hex wrench 6mm.
2. Remove the encoder cable using a small flathead screwdriver.
3. Loosen the locking bolt of the encoder using a 3mm hex wrench and loosen the bolt which connects the motor and the encoder bracket with a 8mm hex wrench, then remove the broken encoder.

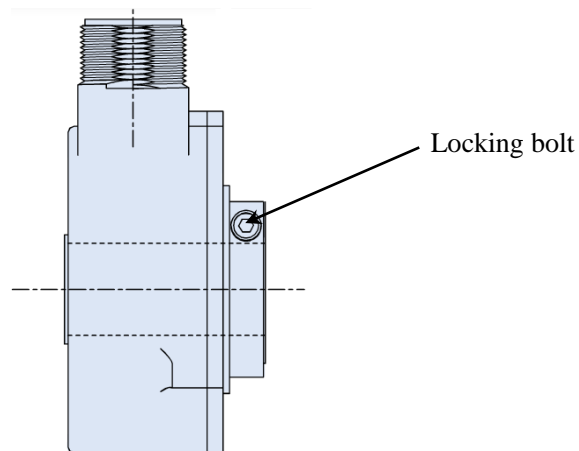

Figure 22 Encoder

8.1.2 Encoder mounting instructions

1. Attach the encoder bracket to the encoder so the cable connection is near the opening of the cover.
2. Check new encoder by slowing spinning to check for a smooth operation before installing.
3. Clean the motor shaft with clean cloth, then slip the new encoder on to the shaft.
4. Tighten the bolt into the motor through the encoder bracket with a 8mm hex wrench and tighten the locking bolt with the 3mm Hex wrench.
5. Connect the encoder and the transducer cable, and install the encoder cover.

8.2 Brake Switch Replacement



Please refer to the troubleshooting procedure first and make sure that the switch is actually bad before performing this replacement procedure.

8.2.1 Normal Brake Switch Replacement

Required Tools & Materials:

Brake switch

Phillips screwdriver

Small flathead screwdriver

Loctite 290

Multimeter

Adjustable end wrench

Feeler gauges:1mm

8.2.1.1 Normal Brake switch removal instructions

1. Loosen the bolts and the washers in the brake terminal box using a Phillips head screwdriver, and remove the terminal box cover.
2. Remove the cable of the brake switch that needs to be replaced from the brake terminal using a small flathead screwdriver.
3. Loosen the composite slot screw M4x10 using a Phillips head screw driver, then remove the broken switch with bracket.

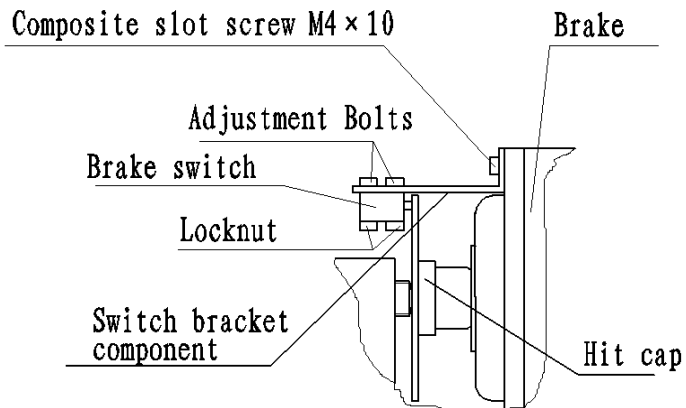

Figure 23 Normal Brake switch mounting

8.2.1.2 Normal Brake switch mounting instructions

1. Clean the switch bracket component mating surface if it is not clean.
2. Install the brake switch and the bracket component on the brake surface using the composite slot screw M4x10.
3. Reconnect the new brake switch cable.

8.2.1.3 Normal Brake Switch adjustment

1. Loosen the adjustment bolts using a Phillips head screwdriver and adjustable end wrench, and adjust the position of the brake switch.
2. Place a 1mm feeler gauge between the Hit cap and the brake switch, and adjust the switch slowly. When the switch operates, tighten the adjustment bolts and locknuts and remove the feeler gauge.

Note: Multimeter can be used to determine when the new switch operates.

3. Apply loctite 290 between the screw heads and the switch body.

8.2.2 Emergency Brake Switch Replacement

Required Tools & Materials:

Brake switch

Phillips screwdriver

Small flathead screwdriver

Loctite 290

Multimeter

Open end wrench: 7mm (x 2)

Feeler gauges: 1mm

8.2.2.1 Emergency Brake switch removal instructions

1. Remove the two (2) Screws M3X10 and then remove the terminal box cover. See Figure 19 on page 25.
2. Remove the brake switch cable in the terminal box using a small flathead screwdriver.
3. Remove the two (2) Screws M4X10 and then remove the Brake switch with plate.
4. Remove the two (2) bolts M4X30, Nuts M4, washers-4 and lock washers-4 and then remove the brake switch.

8.2.2.2 Emergency Brake switch mounting instructions

1. Clean the mating surface of the Plate and new Brake switch.
2. Place the new Brake switch on the Plate, insert the two (2) Bolts M4X30 and washers-4, washer-4, lock washer-4 and Nuts M4 to tighten.
3. Install the Brake switch with plate and then tighten with two (2) screws M4X10 and washers-4; attach the wires from the new Brake switch to the terminal box.

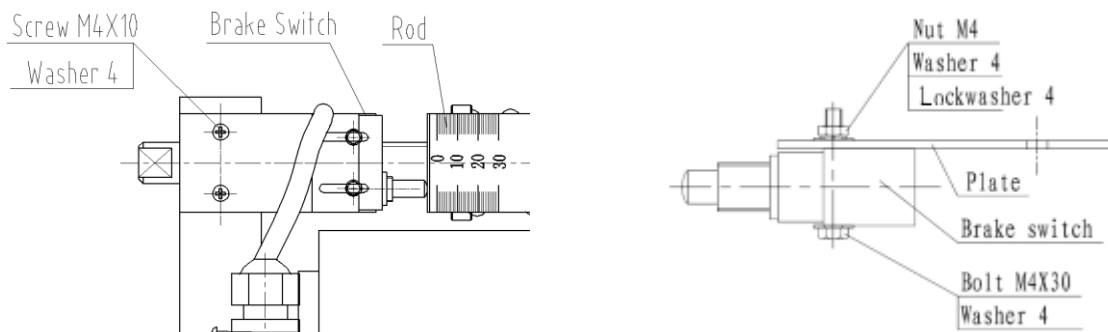

Figure 24 Emergency Brake Switch Replacement

8.2.2.3 Emergency Brake Switch adjustment

1. Loosen the bolts M4x30 using a 7mm open end wrench (X2), and adjust the position of the brake switch.
2. Adjust the Brake switch's position: Close the brake, loosen the Nut M4 and adjust the Brake switch's position so a 1mm (0.04") feeler gauge can be squeezed between the brake switch and the rod does not trigger the switch, but a 2mm (0.79") feeler gauge does trigger the switch.
3. Apply loctite 290 between the bolt heads and the switch body.

8.3 Motor Replacement



Please refer to the troubleshooting procedure first and make sure that the motor is actually bad before performing this replacement procedure.

Required Tools & Materials:

Hoisting equipment

Open end wrench: 24mm

Clean cloth

Lubricating oil

Torque Wrench

Philips screwdriver

8.3.1 Motor removal instructions

1. Remove the elevator from service.
2. Land counterweights on buffers and hang car in hoist way with properly rated hoisting equipment.
3. Install rope block in machine room or hoist way, whichever is more applicable.
4. Hoist car until there is enough slack to remove the ropes from the drive sheave in the machine room.
2. Remove the encoder from the motor, for information regarding how to remove the encoder, please refer to this manual, Section 8.1 Encoder Replacement.
3. Remove the motor terminal box cover, label motor leads, and then disconnect.
4. Install proper hoist and rigging over the motor, and hoist the motor until light pressure is applied to the rigging.
5. Remove the Bolts (4) M16x65 and washers.

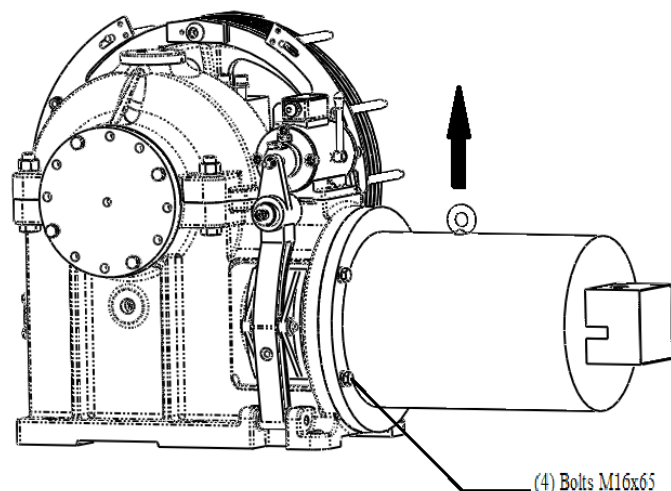

Figure 25 Motor Replacement

6. Move the motor away from the traction machine.
7. Place large blocks on the ground, below the motor, and lower the motor onto the blocks. The blocks should be large enough to support the motor.

8.3.2 Motor reassembly instructions

1. Apply some lubricating oil on the flexible coupling, hoist the motor and keep level, make the position of the motor coupling's keyway and the position of the brake drum's keyway opposite of each other. (Note: Mark the encoder end of the motor shaft in line with the key to make alignment easier.)
2. Tighten the bolts (4) M16x65 and washers to 125Nm - 150Nm (92 ft-lb - 110 ft-lb).
3. Turn the motor and measure the radial travel movement (brake float) of the brake drum, it should be no more than 0.004" if using a dial indicator.
4. Re-connect the motor leads, and double check wiring before closing motor terminal box.
5. Re install the encoder, please refer to this manual, Section 8.1.2 Encoder Mounting Instructions.
6. Place hoist ropes back onto drive sheave in machine room and then begin lowering with the elevator, while slowly apply pressure back onto the hoist ropes. Double check to make sure the ropes are in the proper grooves before continuing on. Remove rope block and rigging equipment from car top before proceeding.

8.4 Brake Replacement



Please refer to the troubleshooting procedure first and make sure that the brake is actually bad before performing this replacement procedure.

8.4.1 Normal Brake Replacement

Required Tools & Materials:

Hex wrench (6mm)

Phillips screwdriver

Small flathead screwdriver

8.4.1.1 Normal Brake Removal Instructions

1. Remove the elevator from service, and land the counterweights on the buffers. Lock and tag out before removing the brake cable and the brake switch cable from the brake terminal box.
2. Loosen the hexagonal bolts (4) M8x20 and washers with 6mm hex wrench, and remove the broken brake from gear box.

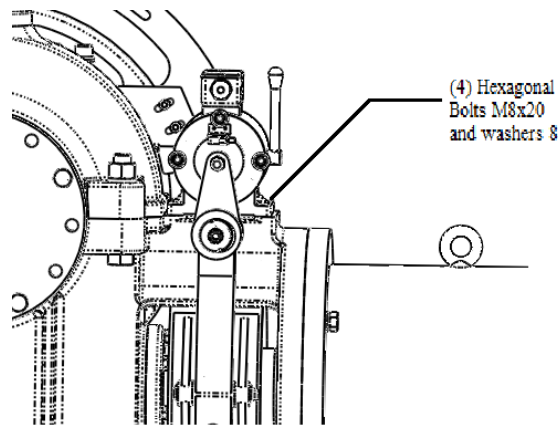

Figure 26 Normal Brake Removal

8.4.1.2 Normal Brake Mounting Instructions

1. Install the new brake onto the geared box, and attach it with the bolts (4) M8x20 and lock washers, but do not tighten.
2. Adjust the position of the brake, make the axis of the solenoid, the Spring Threaded Stud and the Stroke Adjustment Bolt aligned in the same plane, and tighten the bolts (4) M8x20, make the position of the brake secure.
3. For Normal Brake Torque Adjustment refer to this manual section 6.1.1 & for Stroke adjustment see section 6.2.1.

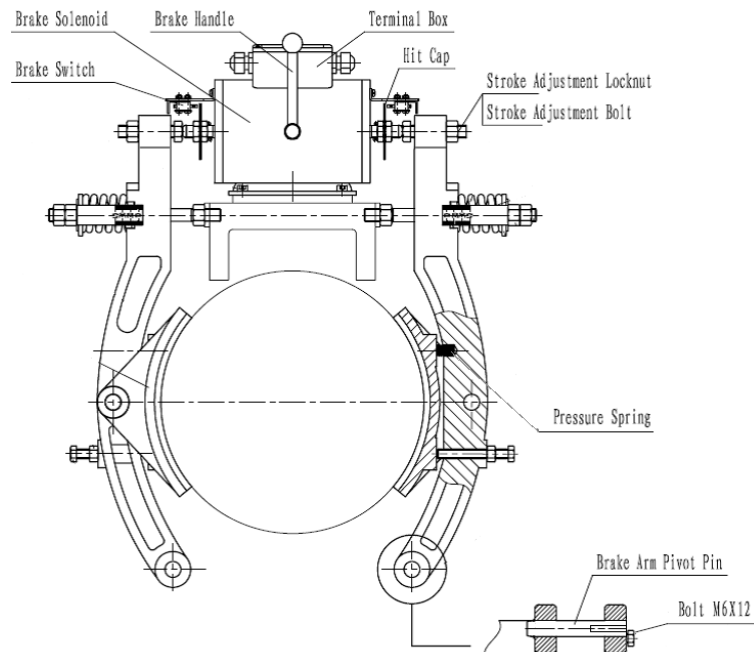

Figure 27 Normal Brake

8.4.2 Emergency Brake Replacement

Required Tools & Materials:

Open end wrench: 7mm, 13mm, 19mm, (2x) 30mm

Phillips screwdriver

Small flathead screwdriver

Feeler gauge

Rubber hammer

Torque Wrench (60Nm,) (45 ft-lb)

Loctite 243

Snap Ring pliers

NOTE: This procedure removes the complete emergency brake. If only the coil is bad follow steps 1-11

8.4.2.1 Emergency Brake removal instructions.

1. Remove the elevator from service, and ensure proper operation the primary brake before proceeding with any work on the emergency brake.
2. Remove the terminal box cover and disconnect the wiring to the brake. See figure 28.
3. Remove the two (2) Screws M4X10 and then remove the Brake switch and plate. See figure 29.
4. Remove the two (2) Screws M4X10 and then remove the Rod. See figure 29.
5. Loosen the Nut M20 and Thin nut M20, freeing the spring. See figure 30.
6. Remove the Stud retaining pin.
7. Remove the Nut M20, Thin nut M20 and Washer 20 (Both sides of brake coil). See figure 30.
8. Remove the two (2) snap rings, then use the screwdriver and Rubber hammer to push the Pin out of the Brake arm part I. See figure 30.
9. Remove the Brake arm part I.
10. Remove the Stud (Including Nuts and spring). See figure 30.
11. Remove the broken Brake. See figure 30.
12. Loosen the (4) bolts M16X75 lock washers 16 and then remove the brake support and brake arm part II from the support. See figure 30.
13. Use the Screwdriver and Rubber hammer to push the Pin out of the Brake arm part II.
14. Remove the Brake arm part II from the brake support. See figure 30.

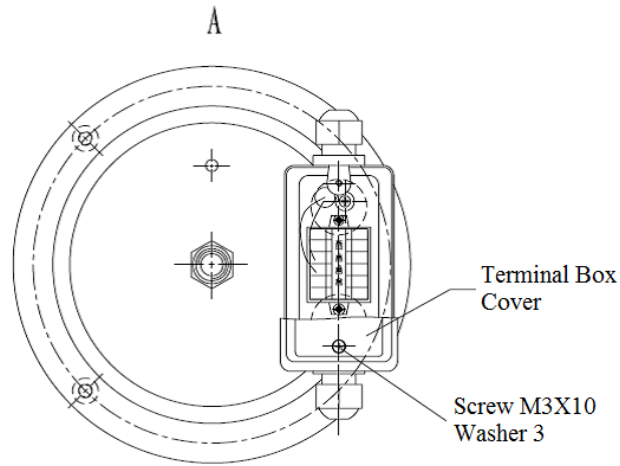

Figure 28 Emergency Brake Terminal box

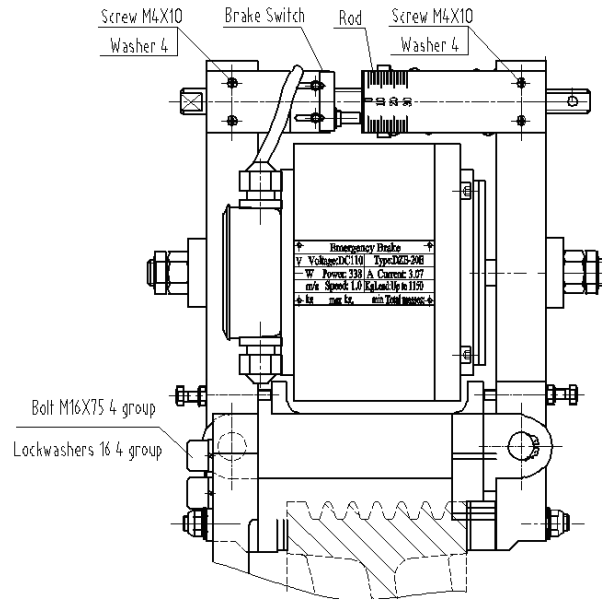

Figure 29 Emergency Brake

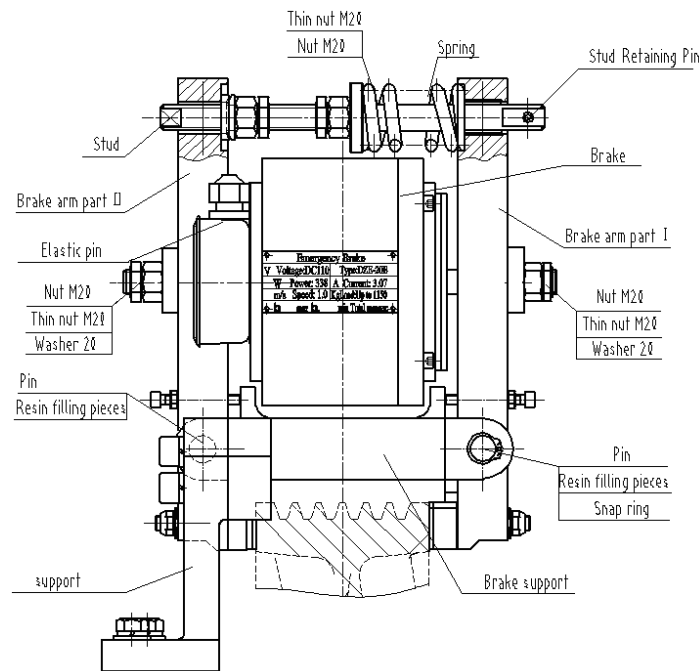

Figure 30 Emergency Brake Replacement

NOTE: If you are only replacing the brake coil follow steps 4 - 14

8.4.2.2 Emergency Brake mounting instructions

1. Place the Brake arm part II into the Brake Support; put two (2) Resin filling pieces into the gap which between Brake arm part II and Brake Support (both sides). See figure 31.
2. Insert the Pin into the hole from Brake Support to Brake arm part II. See figure 31.
3. Install the Brake support onto the Support, and attach it with (4) Bolts M16X75 and lock washers 16.
Note: Put the Elastic pin 6X35 of brake into the hole of Brake arm part II. See figure 32.
4. Install the new Brake into the hole of Brake arm part II. See figure 32.
5. Install the stud (Including Spring, Nuts and Gasket) into the hole of Brake arm part II. See figure 32.
6. Place the Brake arm part I into Brake Support. See figure 33.
7. Put the two (2) Resin filling pieces into the gap which is between Brake Arm Part I and Brake Support (one on each side).
8. Insert the Pin into the hole from brake support to Brake arm part I.
9. Install the two (2) snap rings onto the Pin.
10. Install the washer 20, thin nut M20 and nut M20 (both sides of Brake).

11. Re install the brake switch with plate and rod with screws M4x10.
12. Tighten the Nut M20 and Thin nut M20 of Stud to compress spring and reinstall Stud Retaining Pin.
13. For Emergency Brake Torque Adjustment refer to this manual section 6.1.2 & for Stroke adjustment see section 6.2.2.
14. Reconnect the wiring in the terminal and place the cover on terminal box.

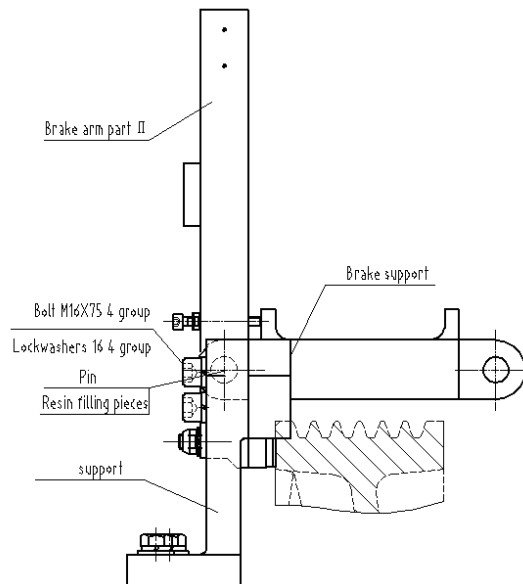

Figure 31 Emergency Brake Installation

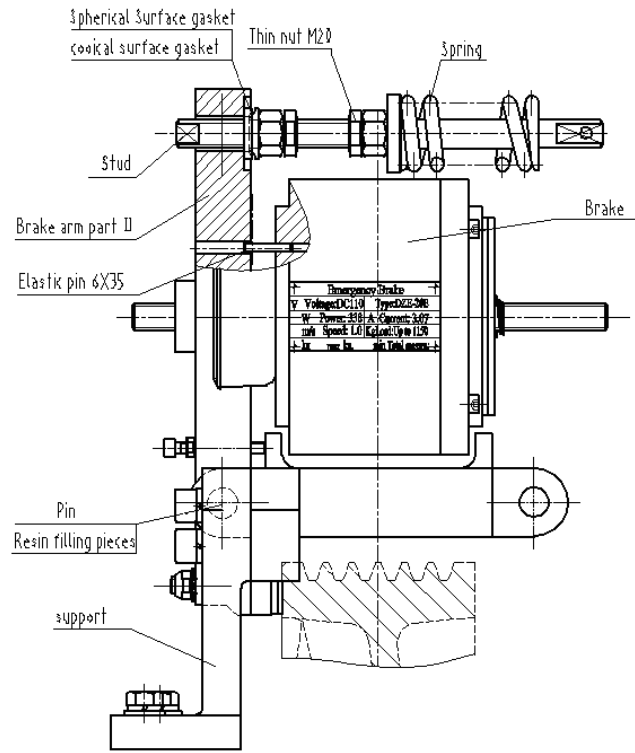

Figure 32 Emergency Brake Installation

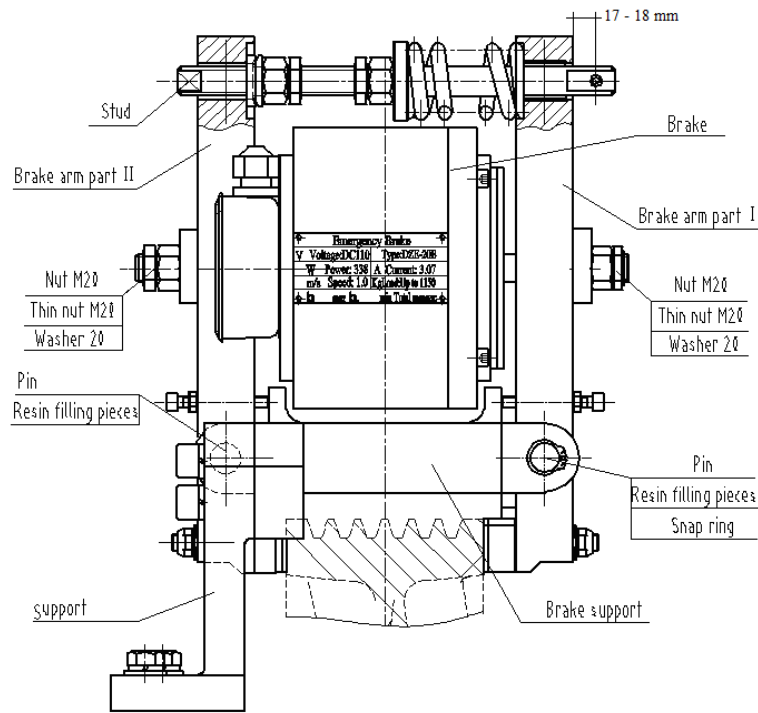

Figure 33 Emergency Brake Installation

8.5 Brake Lining Replacement



Please refer to the troubleshooting procedure first and make sure that the Brake Lining is actually bad before performing this replacement procedure.

If the brake lining wears more than 2mm, the brake lining must be replaced or replace the whole brake arm assembly.

8.5.1 Normal Brake Lining Replacement

Required Tools & Materials:

Open end wrench: 10mm, 18mm

Hex wrench: 6mm

Flathead screwdriver

Hammer

Snap ring pliers

M6x50 bolt

M8x50 bolt

8.5.1.1 Normal Brake Lining removal instructions

1. Remove the elevator from service, and make sure the counterweights are landed on the buffers.
2. Loosen the spring adjustment nut & washer, taking the pressure off the brake spring. See figure 34.
3. Remove the set screws M6x12 and washers, and install the M6x50 bolt into the end of the brake arm pivot pin.
4. Remove the brake arm pins by pulling on the bolt installed in Step (3).
5. Remove the spring adjustment nut, washer & brake spring. On the sheave side also remove the spring threaded stud.
6. Remove the brake arm, and move it away from the machine.
Note: This brake arm is not heavy enough to require rigging and can be remove by hand.
7. Remove the snap ring, and remove the pin with a hammer and a bolt M8x50.
8. Remove the worn brake lining and loosen the stop Screw M12x65 and Nut M12.

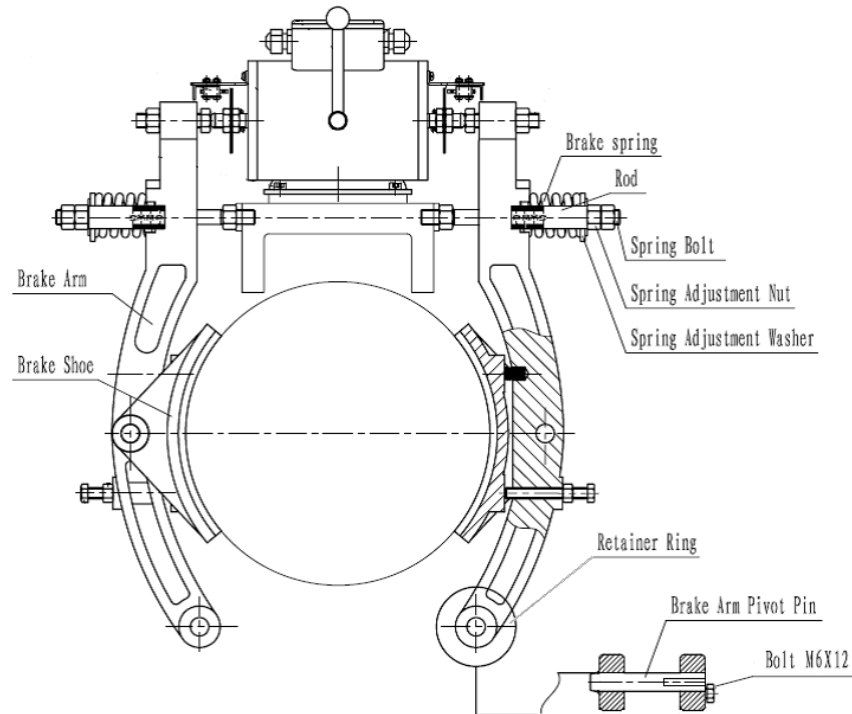

Figure 34 Normal Brake Lining

8.5.1.2 Normal Brake Lining installation instructions

1. Clean the brake arm and new brake lining with clean cloth.
2. Install the pressure spring into the hole of the brake arm, and attach the brake lining with the pin and the snap ring. See figure 34.
3. Install the brake arm assembly into the gear box with the brake arm pivot pin and secure it with the bolt M6x12 and washer.
4. Install the spring threaded stud, (on the sheave side) brake spring, spring adjustment nut, and adjustment washer.
5. For Normal Brake Torque Adjustment refer to this manual section 6.1.1 & for Stroke adjustment see section 6.2.1.

8.5.2 Emergency Brake Lining Replacement

Required Tools & Materials:

End wrench: 7mm, 13mm, 19mm, (2x) 30mm

Screwdriver

Dial indicator

Feeler gauge

Rubber hammer

Torque Wrench (60Nm) (45 ft-lb)

Loctite 243

Note: Brake arms must be removed prior to replacing emergency brake lining. See Section 8.4.2.1

8.5.2.1 Emergency brake lining removal instructions

1. Remove the Locked nut M12 from the Brake arm. See figure 35.
2. Remove the Brake lining part from the Brake arm.

Note: Do not lose the Elastic pin 6X26 when removing the Brake lining part.

3. Remove the bolt, separate Brake lining from the support. See figure36.

8.5.2.2 Emergency brake lining installation instructions

4. Clean the mating surface of the support and new brake lining.
5. Apply Loctite 243 on bolt see figure 36 below. Tighten bolt to 60Nm (45 ft-lb).
6. Place the Brake lining part into the hole of Brake arm part put two (2) washers 12 and tighten the bolt with locked nut M12, then the locked nut M12 must be unscrewed one half turn. **Note: Tighten the locked nut M12 to get the measurement $63\pm 0.2\text{mm}$. See figure 37.**
7. Reassemble the Emergency Brake arms, refer to this manual Section 8.4.2.2 Emergency Brake mounting instructions
8. For Emergency Brake Torque Adjustment refer to this manual section 6.1.2 & for Stroke adjustment see section 6.2.2.

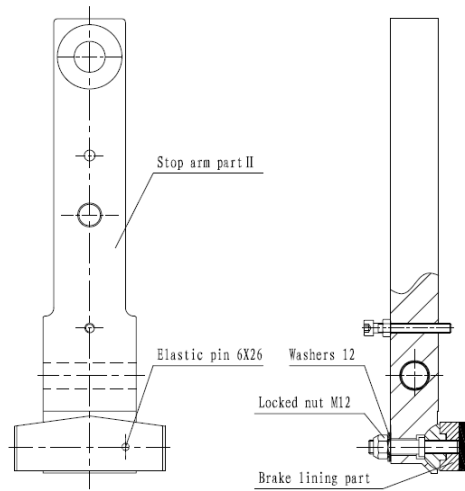

Figure 35 Emergency Brake Arm

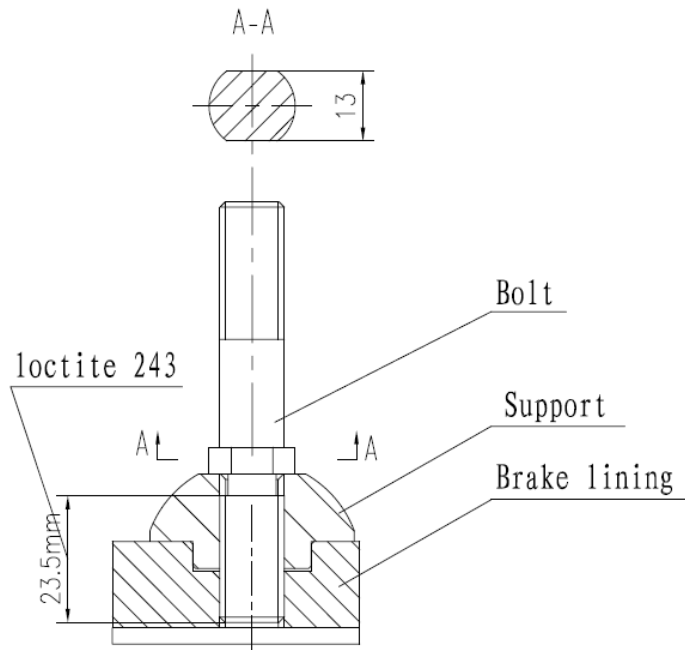

Figure 36 Emergency Brake Lining

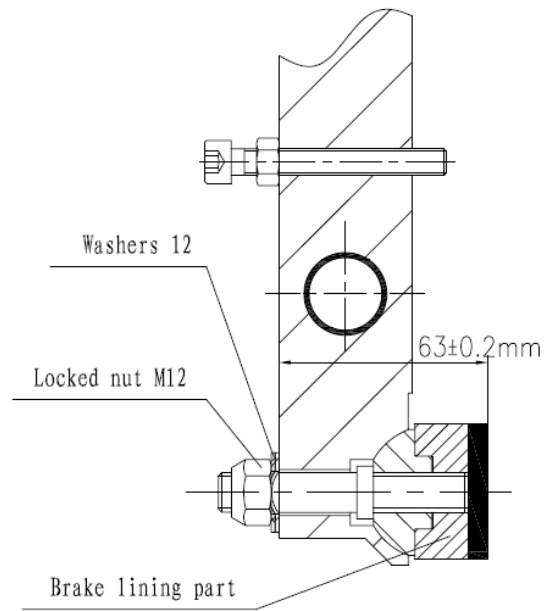

Figure 37 Emergency Brake Lining Replacement

8.6 Sheave replacement



Please refer to the troubleshooting procedure first and make sure that the sheave is actually bad before performing this replacement procedure

Required Tools & Materials:

Hoisting equipment

Torque wrench 136Nm (100 ft-lb)

Dial indicator

Open end wrench: 18mm, 36mm

Arm puller

Clean cloth

8.6.1 Sheave removal instructions.

1. Remove the elevator from service, hang the elevator in hoist way with the proper hoisting and rigging equipment. Add a rope block and then begin hoisting the car until you have enough slack in the ropes to remove them from the drive sheave, but do not attempt to remove ropes until emergency brake is removed.
2. Make sure to trip the governor as a secondary safety device.
3. If the machine has the Emergency Brake, loosen the Bolt M16X60, then remove the Emergency Brake and Support. See figure 38.
4. Remove the Nut M24 with open wrench 36 mm to remove rope retainers.

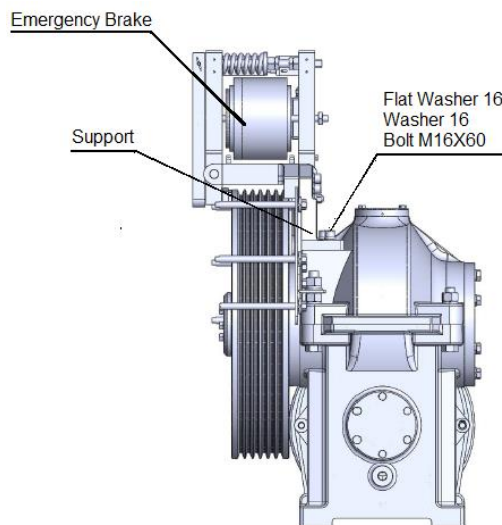

Figure 38 Sheave Replacement Emergency Brake removal

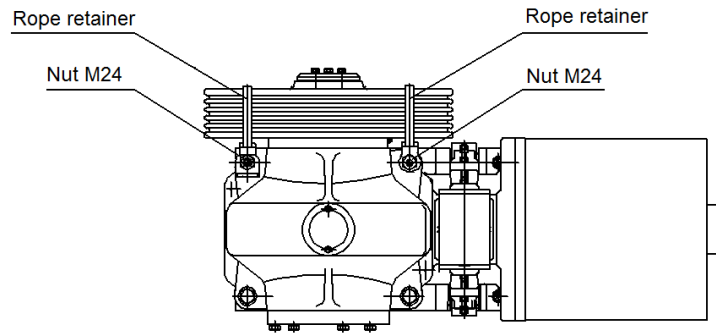

Figure 39 Sheave Replacement Rope Retainer

5. Remove the hoisting ropes from the drive sheave.
6. Install a 1/2-ton hoist and rigging around the sheave. See figure 41.
7. Hoist the sheave until a slight pressure is applied to the rigging.
8. Remove the three (3) drive sheave retaining bolts by 18mm open end wrench, and remove the drive sheave retainer. See figure 40.
9. Use the puller to pull the drive sheave off the output shaft. Protect the threaded hole in the center of the shaft.
10. Once the drive sheave has been removed, the key can be removed using an M6x40 or longer bolt turned in to the threaded opening in the key. Note: If the key is removed, clean the keyway and key before reinstallation.

NOTE: The output shaft and sheave carrier are tapered. Once the sheave is moved a small amount, it can be removed by hand.

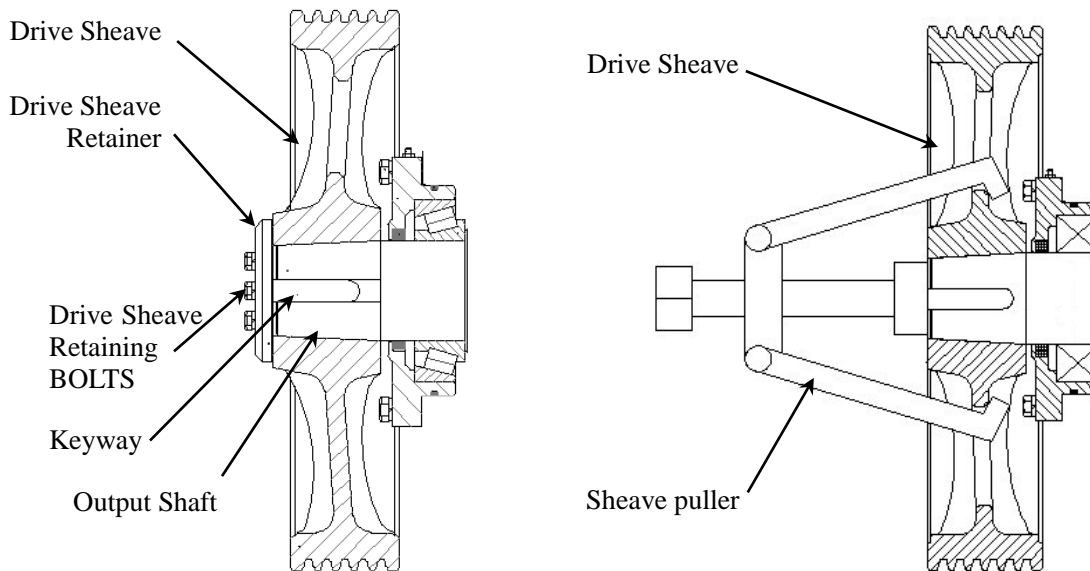

Figure 40 Sheave removal

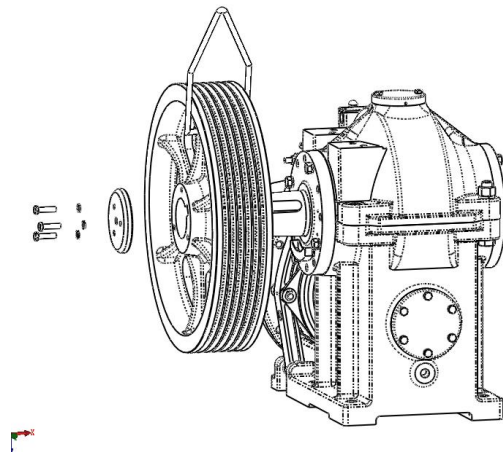

Figure 41 Sheave Replacement

8.6.2 Sheave installation instructions.

1. Ensure the replacement sheave keyway is also in the same position as the removed sheave. This will make it easier to line up the drive sheave and the output shaft keyways.
2. Hoist the replacement sheave into place.
3. Replace the drive sheave retainer and align the three (3) inner holes in the output shaft.
4. Insert, thread, and hand tighten the three (3) drive sheave retaining bolts.
5. Tighten the three (3) drive sheave retaining bolts to 136 Nm (100 ft-lb).
6. Clean the rope groove of the drive sheave-this will be used as an indicator surface.

7. Attach a dial indicator to the machine, over the drive sheave, between the 12 o'clock and the 1 o'clock position. Set the indicator to measure the side of the cleaned rope groove. See figure 42.

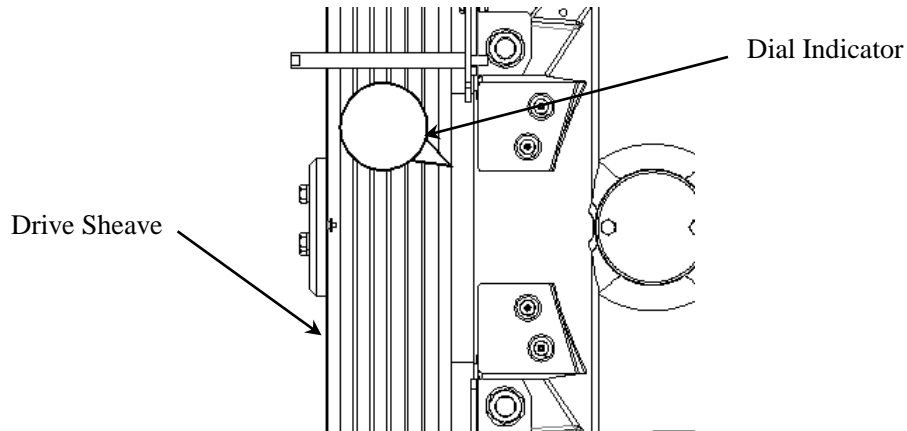

Figure 42 Sheave Replacement TIR

8. Rotate the drive sheave until the least reading of the dial indicator. Set the dial indicator to “0”. This will become the reference point for adjusting the weave of the drive sheave,
9. With the dial indicator, check for TIR of $\leq 0.25\text{mm}$ (0.01”) by rotating the drive sheave clockwise one (1) complete revolution.
10. Reinstall the ropes.
11. Begin lowering the car until ropes are holding the hoist is no longer handling any loads, and remove the hoisting and rigging equipment securing the car.
12. Release the safety and the governor.
13. Turn ON the mainline disconnect.
14. With the weight now on the drive sheave, run the car down and up a few landings.
15. Repeat the measurements in Step 7 and 8 to ensure the weave of the drive sheave has not changed.
16. Reinstall the rope retainers and tighten the two (2) nuts M24.
17. Reinstall Emergency Brake if removed earlier.
18. Cycle car and check for any signs of vibration and/or heat, before releasing the elevator back to the public.

8.7 Ring Gear Replacement



Please refer to the troubleshooting procedure first and make sure that the component is actually bad before performing this replacement procedure.

Required Tools & Materials:

Open end wrench 16mm 24mm

Hammer

Dial indicator

Color ink (Blue ink aerosol)

Hoisting equipment

Clean cloth

M4x50 hexagonal bolt

M10 eye bolt & M16 eye bolt (optional)

Torque wrench 106Nm (80lb-ft)

Adjustable wrench

Sealant

Bearing Heater or Map Gas (Outside heat source)

8.7.1 Ring Gear replacement instructions

1. Remove the sheave. Refer to this manual section 8.6.1 Sheave removal instructions.
2. Remove bolts M10x35 with a 16mm open end wrench and then drain the oil from the gearbox.

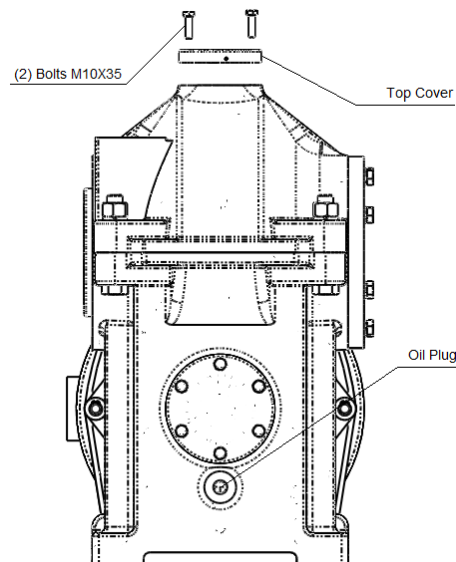

Figure 43 Oil drain

- Thread a M4x50 bolt into each of the two drive pins on the gear box top. Close a large adjustable end wrench on the bolt below the head. Use a hammer or mallet against the wrench to remove the drive pins. See figure 45. Loosen the Bolts M16x60 from the Spindle Through-Cover and the Bolts M16x50 from the Bearing Gland. Then remove the spindle through cover and bearing gland. See figure 44.

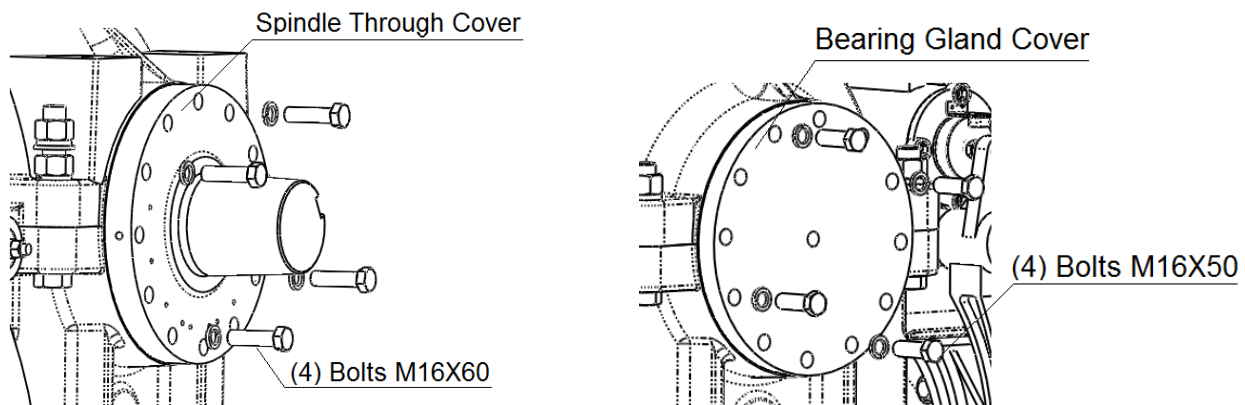

Figure 44 Spindle through Cover and Bearing Gland removal

- Loosen the Nuts M24, the Bolts M24x170 and the Bolts M24x140.

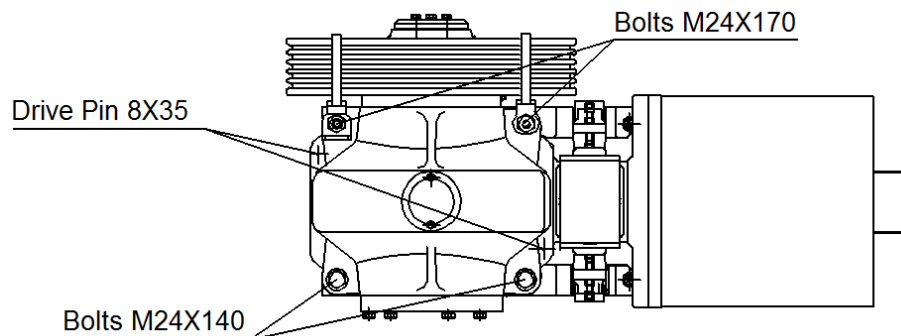

Figure 45 Top housing

- Install M10 eye bolt on top of housing so it can be hoisted from the machine.

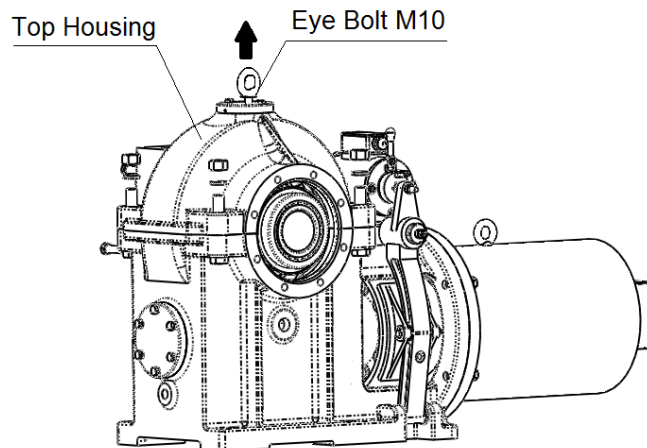

Figure 46 Top housing removal

6. Place two stands approximately 12” apart in an area of the machine room with enough clearance to work the output shaft and ring gear.
 7. Hoist the output shaft assembly from the bottom housing, and lower onto stands. See Figures 47 and 48.
- Note: Stands should support the output shaft, NOT the gear.**
8. Place some protective material between the ring gear and the stands.
 9. With the assembly resting on the stands, remove the output shaft sling, and set the sheave side of the output shaft pointing down. See figure 48.

Note: An M16 eye bolt may be threaded in to the end of the output shaft.

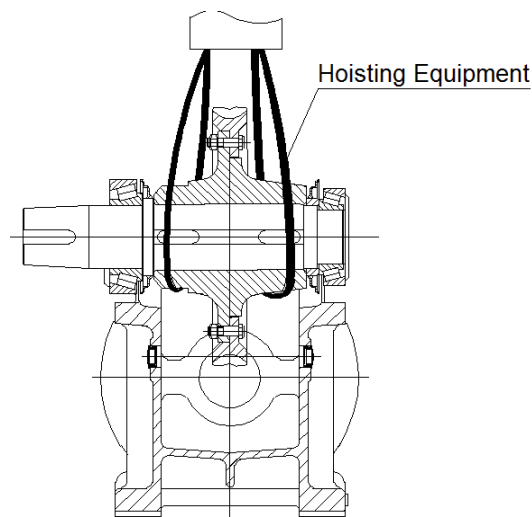

Figure 47 Output shaft hoisting

10. Remove the six (6) M16 bolts that secure the ring gear to the shaft flange and remove the gear.

NOTE: Write down the position of the ring gear bolts, washers and nuts. The new material is to be installed in the same position.

11. Contact the building engineer to turn off the machine room smoke detectors.
12. Check the mating surface of the new gear and the shaft flange for any debris that may hinder a flush fit.
13. With a gloved hand, set the new gear (with the mating side down on the shaft flange), and gently warm the new gear until it drops onto the gear flange.
14. Once the gear is sitting flush, align the holes to match the shaft flange (drift pins or an existing bolt can be used for alignment).
15. Allow the gear to cool completely, then hand ream the hole from the flange side up. Clean any shavings.
See figure 48.

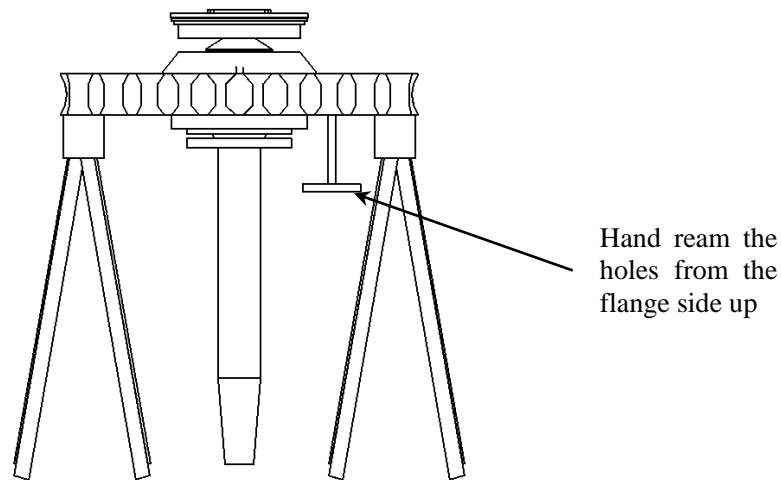

Figure 48 Ring gear support

16. Insert and tighten the bolts M16, washers and nylon insert lock nuts.
NOTE: It may be necessary to use the lock nut to pull the bolt through; turn the lock until the bolt head is flat on the gear surface. Do not hammer the bolts.
17. Torque the lock nuts to 108Nm (80 ft-lb).
18. Hoist the output shaft assembly into the bottom housing.

8.7.1.1 Backlash Adjustment

1. Tighten the bottom housing and the Bearing Gland with the (2) Bolts M16x50, tighten the bottom housing and the Spindle Through-cover with the (2) Bolts M16x60.

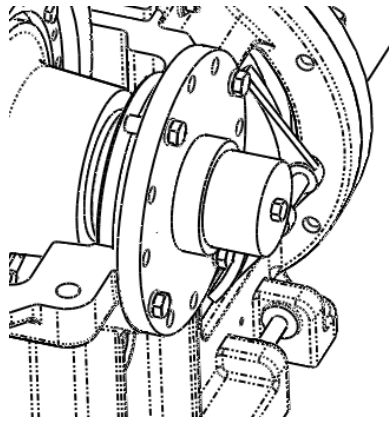

Figure 49 Reinstalling the Spindle through Cover

2. Install the magnetic base of the dial indicator to the bottom housing. See figure 50.



Figure 50 Dial indicator location

3. Rotate the ring gear in one direction, and zero the dial indicator.
4. Rotate the ring gear in the opposite direction, and read the amount of gear movement.
Note: The displacement for a cold machine is ≤ 0.008 ", a hot machine is ≤ 0.006 ".
5. If the displacement is not within specification, turn the bearing gland or spindle through cover one position of the 12 holes in the piece, then recheck. Continue to rotate one or the other until the backlash is within specification.
6. Clean off top three gear teeth on top of ring gear. Using a blue ink aerosol can, spray ink on the three clean teeth (equally spaced around the sheave and on both sides of the teeth), and allow it to dry completely.
7. Place the machine on Inspection Operation and then install top housing, turn on the mainline disconnect and.
8. Run the machine in one direction until the color is wiped off and the pattern can be seen.
9. Repeat Step 8, but run the machine in the opposite direction.

10. Survey the gear pattern carefully for proper wipe.

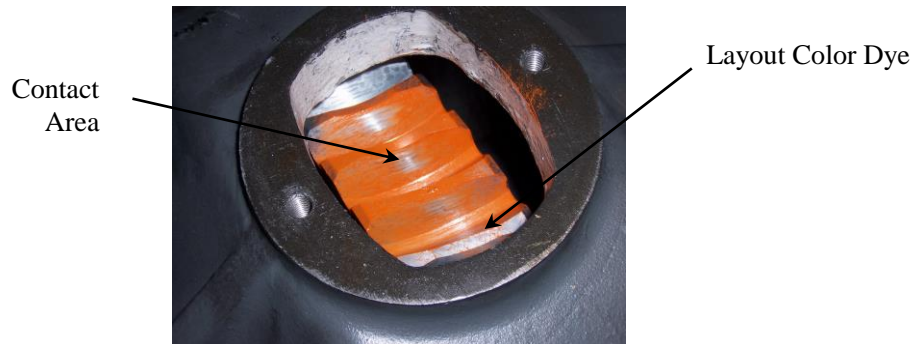

Figure 51 Worm gear contact check

11. Make sure that the Contact Area account for 30% of the direction of the gear's width, and for 55% of the direction of the gear's height. If the Contact Area is to left, increase the shims on the left side cover, or reduce the shims on the right side cover. If the contact area is to right, reduce the shims of the left side cover, or increase the shims of the right side cover. Repeatedly adjust to meet the required specification. Turn off the mainline disconnect
12. Remove top housing with hoisting equipment, clean the mating surface of the bottom and top housing with clean cloth, run a bead of sealant around the surface of the bottom housing.

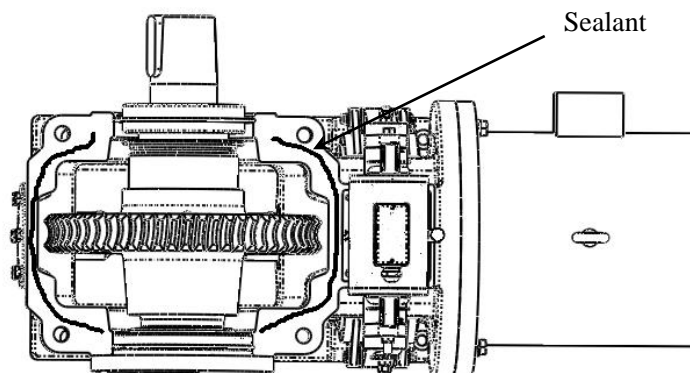

Figure 52 Sealant location

13. Hoist the top housing onto the bottom housing with the hoisting equipment, then tighten them with Bolt M24x170 (2), Bolt M24x140 (2), Nut M24 (4) and lock washer 24 (4).

NOTE: Be careful not to bend any shims when installing the top housing.

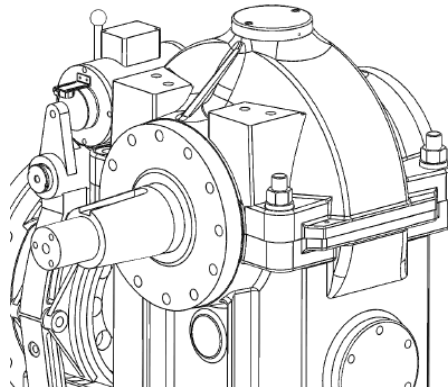

Figure 53 Reinstalling Gear case top

14. Tighten the top (2) Bolts M16x60 to fasten the spindle Through-cover, See Figure 54 and tighten the top (2) Bolt M16x50 to fasten the Bearing Gland.

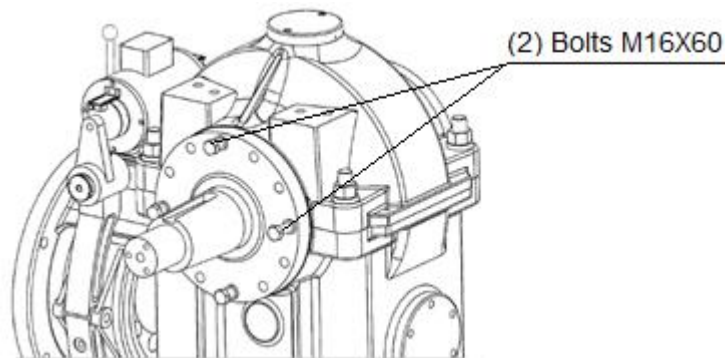

Figure 54 Reinstalling Spindle through Cover

15. Put the drive pins into the gear box, add 13.5L (3.5 gal) elevator oil into the case, fit on the top cover, and tighten it with Bolt M10x35.
16. Connect the mainline disconnect and test the machine.
17. Re install the sheave see section 8.6.2 and emergency brake if so equipped see section 8.4.2.2

8.8 Bearing Replacement



Please refer to the troubleshooting procedure first and make sure that the component is actually bad before performing this replacement procedure. The bearing replacement work must be done on ground, so the machine must be lifted and moved out of the hoist way when performing the bearing replacement work!

Required Tools & Materials:

Hoisting equipment

Bearing heater

Open end wrench: 18mm, 24mm

Wrench with extension & Socket 18mm

Arm puller

3# General purpose lithium lubricating grease

8.8.1 Output shaft bearing replacement

See the step about hoisting the output shaft assembly from the bottom housing. Refer to this manual **Ring Gear replacement instructions Section 8.7.1 Steps 1~8.**

NOTE: Don't damage the seal in the output shaft bearing cover assembly.

1. Remove the bearing 32222 (if the machine has the Emergency Brake, the bearing is 22222EAE4) with the arm puller.

NOTE: Do not damage the internal threads in the sheave shaft with the arm puller.

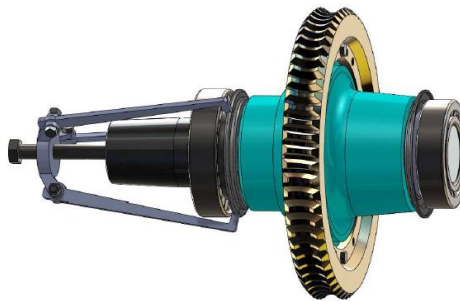

Figure 55 Output Shaft Bearing Removal

2. Place the new bearing in or on the bearing heater. And heat it to about $80 \pm 15^{\circ}\text{C}$. ($180 \pm 59^{\circ}\text{F}$)
3. With a gloved hand, quickly slide the heated bearing fully onto the output shaft.
4. When the bearing has cooled completely, spread grease on the inside lane of the bearing. (Pack the bearing)

5. Apply a small amount of #3 General purpose lithium lubricating grease on the seal of the spindle through cover assembly, and install it to the output shaft.
6. Replace the bearing 32219 (if the machine has the Emergency Brake, the bearing is 6219CM) in the Bearing Gland using the same method, refer on Step 3~6.
7. Hoist the output shaft assembly into the bottom housing, and adjust the Backlash. Refer to this manual Ring Gear Replacement Backlash Adjustment Section 8.7.1.1.

8.8.2 Worm Gear Bearing Replacement

1. Remove the motor. Refer to this manual Motor Replacement Section 8.3 Removal instructions.
2. Remove the brake system. Refer to this manual Brake Replacement Section 8.4 and Brake Lining Replacement Section 8.5 Removal instructions Steps 1~6.
3. Remove the oil plug, drain the oil & reinstall the oil plug.
4. Loosen the Bolt M12x35 and the washer which secures the worm shaft front cover with the M18 mm socket, extension, wrench, and remove the worm shaft front cover.
5. Remove the brake drum with the arm puller, remove key with a M4 bolt.

NOTE: Do not damage the internal threads in the worm shaft with the arm puller.

6. Loosen the (6) Bolt M12x45 and the washer which secures the worm shaft through cover with the M18 mm open end wrench, and remove the worm shaft through cover assembly.
7. Loosen the (6) Bolt M12x45 and the washer from the worm shaft back cover assembly, and remove it.
8. Turn the worm shaft by hand to remove the worm shaft assembly from the bottom housing.
9. Install an arm puller on the bearing, and remove the bearing. The front bearing and the back bearing are the same and can be removed the same way.

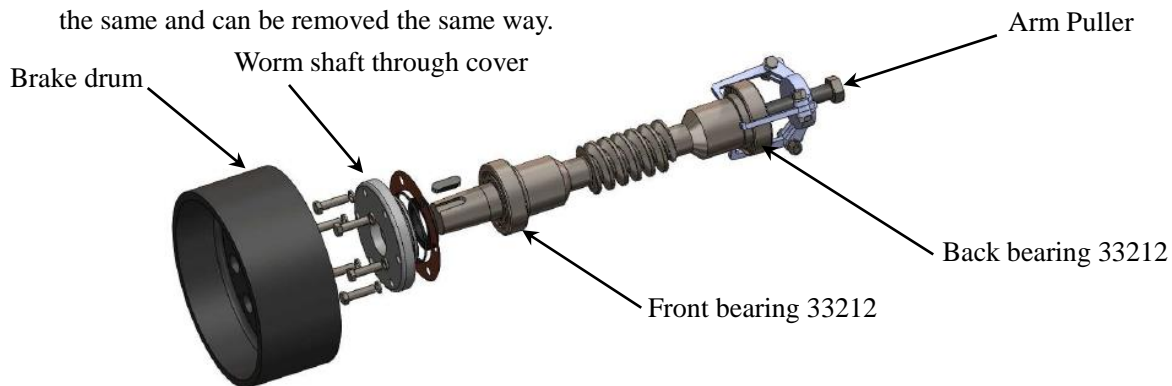

Figure 56 Worm Shaft Bearing Removal

NOTE: Do not damage the internal threads in the worm shaft with the arm puller.

10. Place the new bearings in the heater, and heat bearings to about $80 \pm 15^{\circ}\text{C}$ ($180 \pm 60^{\circ}\text{F}$), while wearing proper heat protecting gloves, quickly slide the heated bearing fully onto the worm shaft and hold it in place for 5 seconds until it sets in place.

Note: Do not wear gloves when do step 11~12.

11. Install the bearing cup for the back bearing into the back bearing bore at the bottom housing, and apply some #3 General purpose lithium lubricating grease on it.
12. Turn the worm shaft by hand to install the worm shaft assembly into the bottom housing, and install the back bearing into the back bearing cup. Apply #3 General Purpose lithium lubricating grease.
13. Install the worm shaft back cover assembly and some shims into the corresponding hole, and screw (2) bolts M12x45 and washers opposite each other, do not over tighten.
14. Place the seal into the worm shaft through cover, and smear some 3# General purpose lithium lubricating grease in it. Place it and washer into the worm shaft motor side, tighten the worm shaft through-cover with the Bolts M12x45 and washers to 50-60 Nm (37-44 ft-lb).
15. Tighten the worm shaft back cover with the Bolts M12x45 and washers to 50-60 Nm (37-44 ft-lb).
16. Place the brake drum into the worm shaft, then install the worm shaft front cover assembly, tighten it with (1) bolt M12x35 and washer, and press the brake drum into the position, note the position of the keyway to install motor conveniently.
17. Measure the radial travel movement (brake float) of the brake pulley and the axial gap of the worm shaft with dial indicator. The radial travel movement (brake float) is no more than 0.1 mm (0.004"), the axial gap is 0.03 mm ~ 0.07 mm (0.0012"~0.003").
18. Loosen the (2) bolts M12x45 and washers to remove the worm shaft back cover, install the seal, and apply some #3 General purpose lithium lubricating grease. And place shims to the back bearing bore, tighten it with (6) bolts M12x45 and washers to 37-44 ft-lb.
19. Check the oil plug is securely tighten, and loosen the bolt M10x35 to remove the top cover, then add 13.5L (3.5 gallons) elevator oil.
20. Install the motor. Refer to this manual Motor replacement Section 8.3.2 Motor Reassembly instructions.
21. Reinstall the Brake system.
22. Connect the mainline and test the machine.

8.9 O-Rings and Seal Replacement



Please refer to the troubleshooting procedure first and make sure that the component is actually bad before performing this replacement procedure

If the machine is leaks oil, the O-Rings and Seal must be examined and replacement.

Required Tools & Materials:

Open end wrench: 18mm 24mm

Wrench, extension & 18mm socket.

#3 General purpose lithium lubricating grease

8.9.1 Replacement on the Output Shaft

8.9.1.1 If the oil leak happened at the Bearing Gland:

1. Loosen the bolts M16x50 and washers (4) and remove the bearing gland, then remove the old O-Ring.
2. Apply some #3 General purpose lithium lubricating grease into the new O-Ring, and install it onto the bearing gland.
3. Tighten the Bolts M16x50 and washers (4).

8.9.1.2 If the oil leak happened at the Spindle through cover:

- a) Remove the sheave. Refer to this manual section 8.6.1 Sheave Removal instructions.
- b) Loosen the bolts M16x60 and washers (4) and remove the spindle through cover, then remove the old O-Ring.

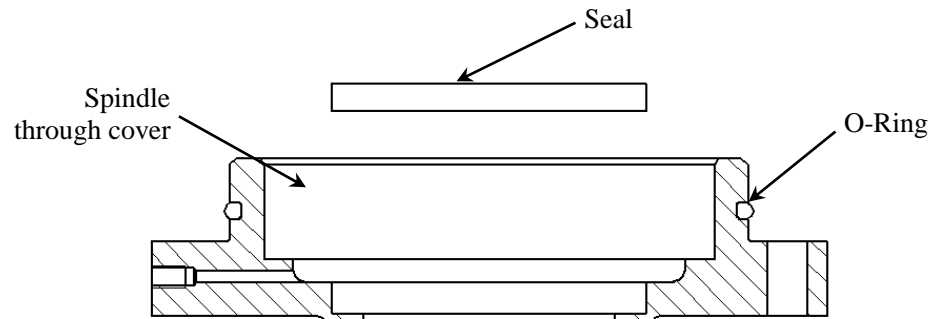

Figure 57 Main shaft seal and O-ring

- c) Remove the bearing cup from the cover, examine the seal and replace it with new one if it damaged.
- d) Apply some #3 General purpose lithium lubricating grease into the new O-Ring, and install it onto the spindle through cover.
- e) Tighten the Bolts M16x60 and washers (4).
- f) Install the sheave. Refer to this manual Sheave Replacement—Method of assembly.

8.9.2 Replacement on the Worm Shaft

1. If the oil leak happened at the worm shaft back cover:
 - a) Drain oil and replace drain plug. Loosen the bolts M12x45 and washers (6) and remove the worm shaft back cover, then remove the old O-Ring.
 - b) Apply some #3 General purpose lithium lubricating grease into the new O-Ring, and install it onto the worm shaft back cover.
 - c) Tighten the Bolts M12x45 and washers (6). Replace oil.
2. If the oil leak happened at the worm shaft through cover:
 - a) Drain oil and replace drain plug. Remove the motor Refer to this manual Bearing Replacement—Worm shaft bearing replacement Section 8.8.2 Steps 1~6.

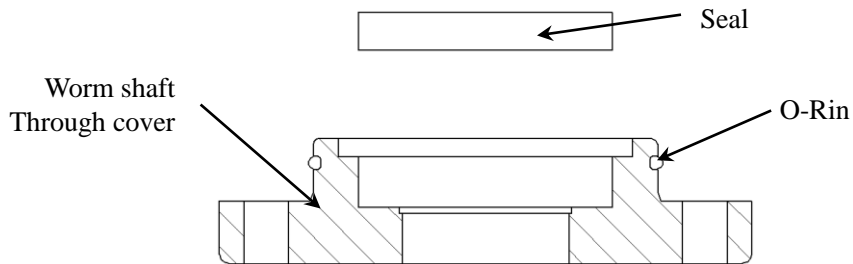

Figure 58 Worm shaft seal and O-ring

- b) Examine the seal and replace it with new one if it damaged.
- c) Apply some #3 General purpose lithium lubricating grease into the new O-Ring, and install it onto the worm shaft through cover.
- d) Reinstall the worm shaft through cover. Refer to this manual Bearing Replacement—Worm shaft bearing replacement Section 8.8.2 Steps 14, 16, 17, 19~22.

9.0 Manual brake release instructions



When the elevator traction machine is running, the brake release lever cannot be installed on the Emergency brake. Only if it's an emergency you can use the manual brake release, you can install it as follows.

9.1 Method of application

1. Install the Brake lever as the following picture
2. Pull up the brake release until the traction sheave can be moved.

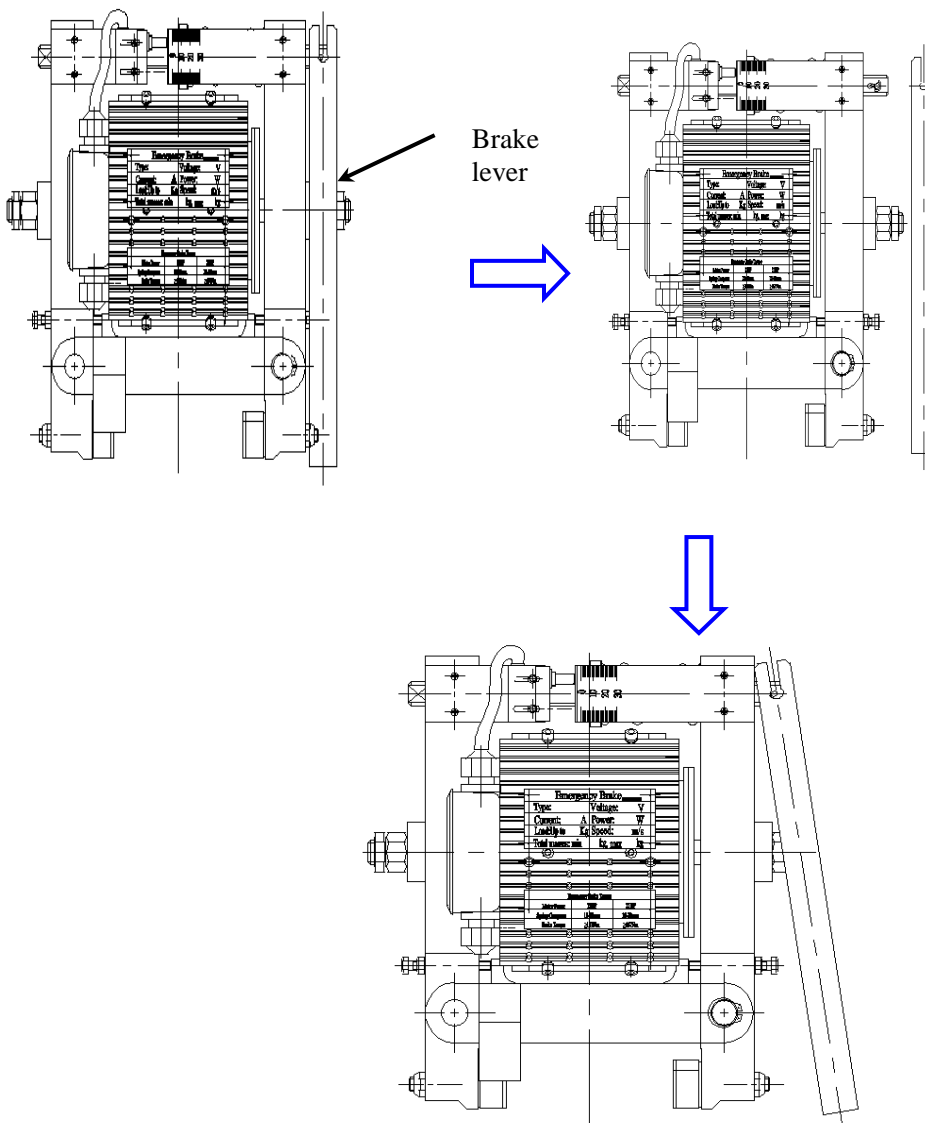

Figure 59 Emergency Brake Manual Release

10.0 Troubleshooting chart



Maintenance for gear machines requires qualified personnel and proper tools.

Faults	Possible causes	Possible solutions
Motor not Working	a. Incorrect inverter wiring	Verify the inverter wiring to make sure it is done correctly
	b. Incorrect inverter parameters	Verify the inverter parameters
	c. Incorrect encoder wiring	Verify the encoder wiring is correct, see section 5.3
	d. Bad Encoder alignment	Verify the inverter alignment procedure is performed correctly
	f. Loose encoder mounting	Tighten the encoder mounting screws, see section 8.1.2
	g. Bad encoder	Replace the encoder, see section 8.1
	h. Bad brakes	Verify the brake operations, see section 7.0
	i. Bad motor contactor	Replace motor contactor
	Abnormal noise or vibration	a. Brake friction noise
b. Bad grounding		Verify that earth ground is correctly install
c. Bad inverter parameters		Make sure inverter parameters are correct
d. Bad encoder feedbacks		Check grounding and shielding.
e. Bad bearings		Replace output shaft or worm bearings see section 8.8.1 or section 8.8.2
f. Bad motor		Replace the motor, see section 8.3
g. Too much pressure in the worm shaft back cover		Loosen the worm shaft back cover, if noise level reduces add 1 or more paper shims to worm shaft back cover
Electrical shocks	a. Bad grounding	Make sure that ground is solid
	b. Bad humidity level	Make sure the humidity is within the specs, see section 1.3
	c. Broken cable insulation	Replace the cable
Brake not working	a. Oil or grease on brake drum	Remove oil from the brake drum & change the brake lining.
	b. Incorrect brake stroke	Readjust the brake stroke, see section 7.2
	c. Brake lining wear out to much	Check the brake lining thickness and readjust the brake stroke or replace the brake, see section 6.2
	d. Bad brake coils	Replace the brake assembly, see section 8.4
	e. Incorrect counterweight percentage	Verify counterweight percentage
	f. Noise absorber height is too big	Reduce the absorber height
Brake switch not working	a. Bad wiring	Verify brake wiring
	b. The position of brake switch not installed correctly	Readjust the brake switch position, see section 8.2.1.3 & 8.2.2.3
	c. Bad brake switch	Replace brake switch, see section 8.2
Motor temperature to high	a. Elevator overload	Verify elevator loading and duty cycle
	b. Incorrect counterweight percentage	Verify counterweight percentage

11.0 Traction Machine Assembly

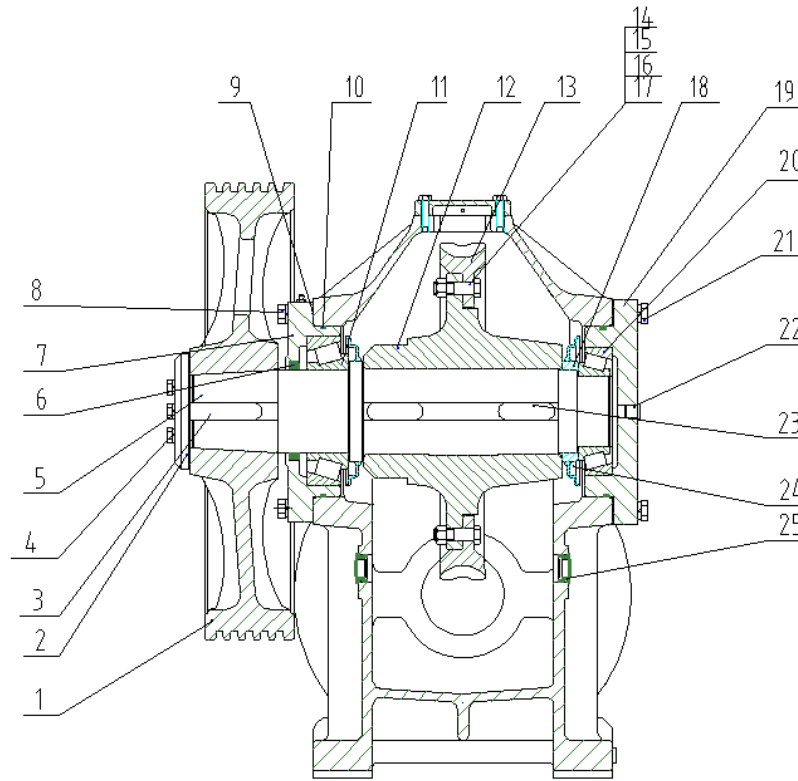

(*)Denotes a non-stock item.

NO.	Torin Drive Part No.	Description
1	MSHV-TGD1	Sheave
	MSHV-TGD1-SB	Sheave with Sheave Brake
2	*	Drive sheave Retainer
3	*	Keyway
4	*	Bolts M12x45 and Washers
5	*	Output Shaft
6	PBR002	Drive Sheave Shaft Seal
7	*	Spindle through-cover
8	*	Bolts M16x60 and Washers
9	See below	Drive Sheave paper shims
	PPS001-0.1	0.1 mm thickness
	PPS001-0.2	0.2 mm thickness
10	PBR014	Output shaft O ring
11	PBR015	Bearing 32222P6 (Drive Sheave side)

12	*	Worm gear flange
13	*	Worm gear
14	*	Nut M12x1.25
15	*	Reamer holes Bolt M12x1.25x50
16	*	Nut M16x1.5
17	*	Reamer holes Bolt M16x1.5x50
18	*	Washer
19	*	Bearing Gland
20	PBR016	Bearing 32219P6 (Opposite Drive Sheave side)
21	*	Bolt M16x50
22	PBR017	Seal lock
23	*	Keyway
24	*	Block oil cap
25	*	Oil scale (view window)

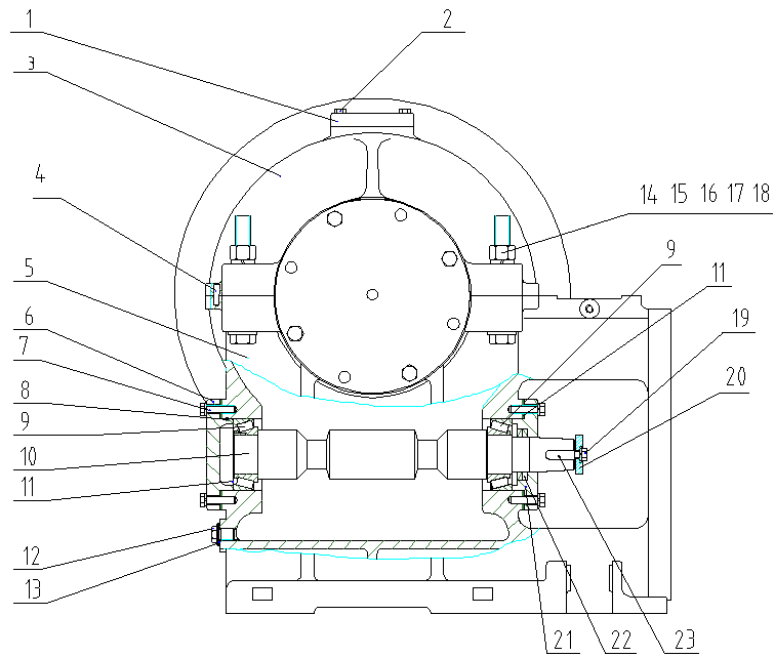

(*)Denotes a non-stock item.

NO.	Torin Drive Part No.	Description
1	*	Top Cover
2	*	Bolt M10x35
3	*	Top gear case
4	PTO004	Drive Pin 8x35
5	*	The bottom housing
6	*	The worm shaft back cover
7	*	Bolt M12x45
8	PBR018	Worm Shaft O Ring
9	PBR001	Worm Shaft Bearing-Koyo 33212JR/33232
10	*	Worm
11	See below	Worm shaft paper shims
	PPS002-0.05	0.05 mm thickness
	PPS002-0.15	0.15 mm thickness
	PPS002-0.5	0.5 mm thickness
12	*	Oil plug M20x1.5
13	*	Oil plug shims
14	*	Bolt M24x140

15	*	Bolt M24x170
16	*	Washer 24
17	*	Washer 24
18	*	Nut M24
19	*	Bolt M12x35
20	*	The worm shaft front cover
21	*	The worm shaft through cover
22	PBR009	TGD1/2 Worm shaft seal-NOK F55*80*12
23	*	Keyway 14x9x45

12.0 Induction Motors & Encoder

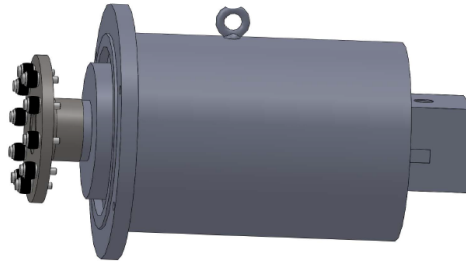

NO.	Torin Drive Part NO.	Motor Description
1	PMNC-2510HV	10 HP (7.5 KW) motor for TGD1-2510. Coupling installed, 460V
2	PMNC-2510LV	10 HP (7.5) KW motor for TGD1-2510. Coupling installed, 2200V
3	PMNC-2520HV	20 HP (15KW) motor for TGD1-2520. Coupling installed, 460V
4	PMNC-2520LV	20 HP (15KW) motor for TGD1-2520. Coupling installed, 220V
5	PMNC-2535HV	25 HP (18.5KW) motor for TGD1-2535. Coupling installed, 460V
6	PMNC-2535LV	25 HP (18.5KW) motor for TGD1-2535. Coupling installed, 220V
7	PMNC-2540HV	30 HP (22.5KW) motor for TGD1-2340. Coupling installed, 460V
8	PMNC-2540LV	30 HP (22.5KW) motor for TGD1-2340. Coupling installed, 220V

NO.	Torin Drive Part NO.	Encoder Description
1	PEN004	HS35F-100-R2-SS-2048-ABZC-28V/V-TB BEI Encoder
2	PEN004A	HS35R2048H37X36 Dynapar Encoder
3	PEN009	Encoder Cap for TGL1/2/3 with Hardware

13.0 Brake Assembly

13.1 Normal Brake Assembly

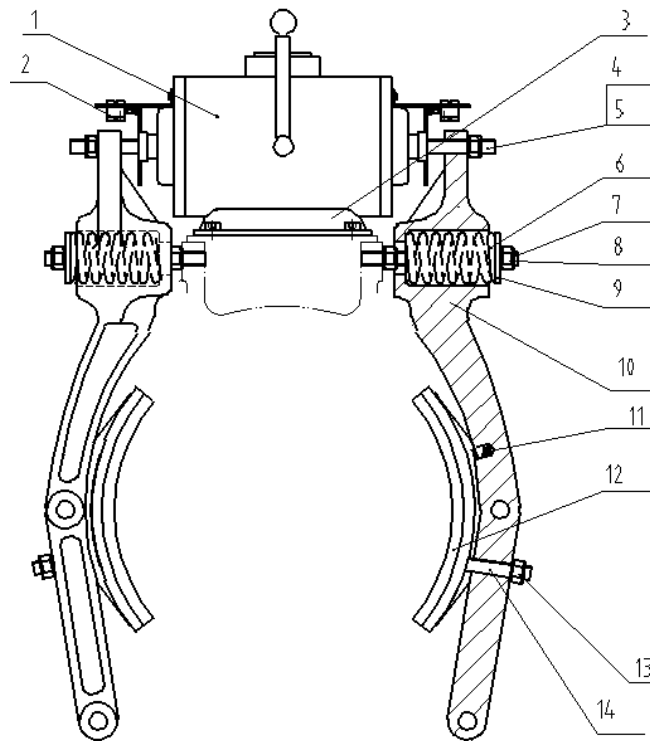

(*)Denotes a non-stock item.

NO.	Torin Drive Part No.	Description
1	PBK013	Normal Brake
2	PSW004	Normal Brake Micro switch
3	*	Bracket
4	*	Bolt M12x65
5	*	Nut M12
6	*	Brake Spring
7	*	Threaded Stud
8	*	Bolt M12x65
9	*	Spring Gland Bush
10	*	Brake Arm
11	PBK034	Pressure Spring
12	PBK020	Brake lining normal brake
13	*	Nut M12
14	*	Bolt M12x65

12.2 Emergency Brake Assembly

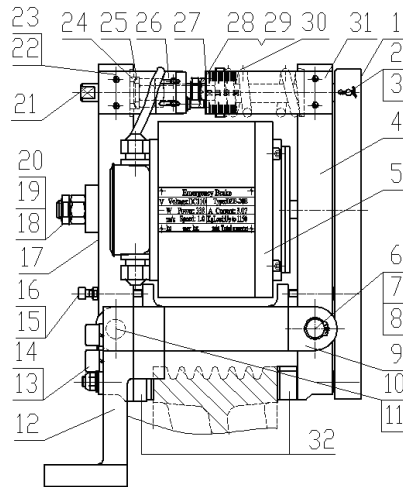

(*)Denotes a non-stock item.

No.	Torin Drive Part No.	Description
1	PBK035	Brake lever
2	*	Pin
3	PBK036	Cotter pin 3.2x15
4	*	Brake arm part I
5	PBK021	Emergency Brake
6	PBK037	Pin
7	*	Snap ring 22
8	PBK038	Resin filling pieces
9	*	Brake support
10	PBK039	Pin
11	PBK038	Resin filling pieces
12	*	Support
13	*	Bolt M16X75
14	*	Nut M16
15	*	Bolt M8X70
16	*	Nut M8
17	*	Brake arm part II
18	*	Nut M20X1.5
19	*	Thin Nut M20X1.5
20	*	Washer 20

21	*	Stud
22	*	Screw M4X10
23	*	Washer 4
24	*	Spherical surface gasket
25	*	Conical surface gasket
26	PSW003	Emergency Brake Micro switch
27	*	Rod
28	*	Nut M20
29	*	Thin nut M20
30	*	Spring adjustment washer
31	PBK040	Spring
32	PBK041	Brake lining, emergency brake
1-32	PBK018	Emergency Sheave Brake Assembly for TGD1

14.0 MECHANICAL DIMENSIONS

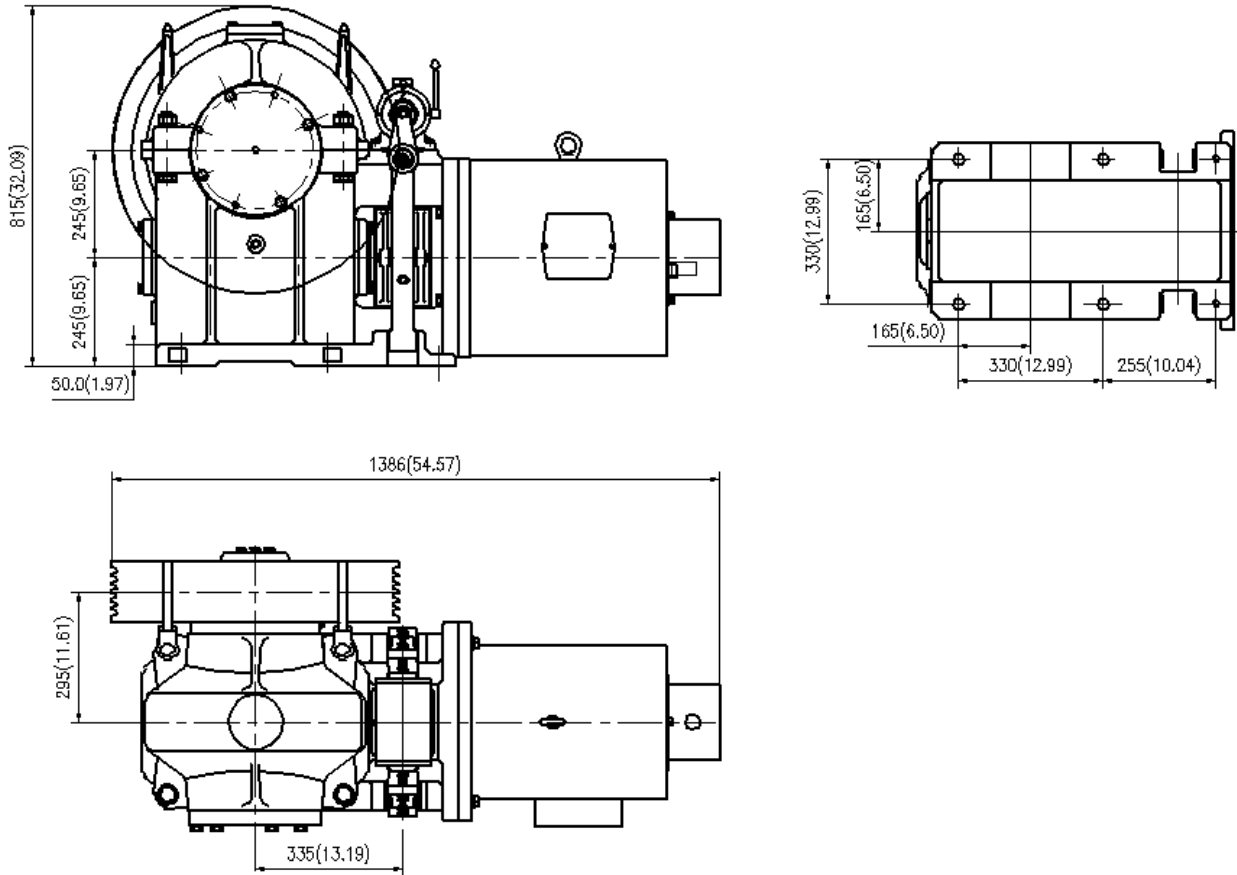

MECHANICAL DIMENSIONS (with Emergency Brake)

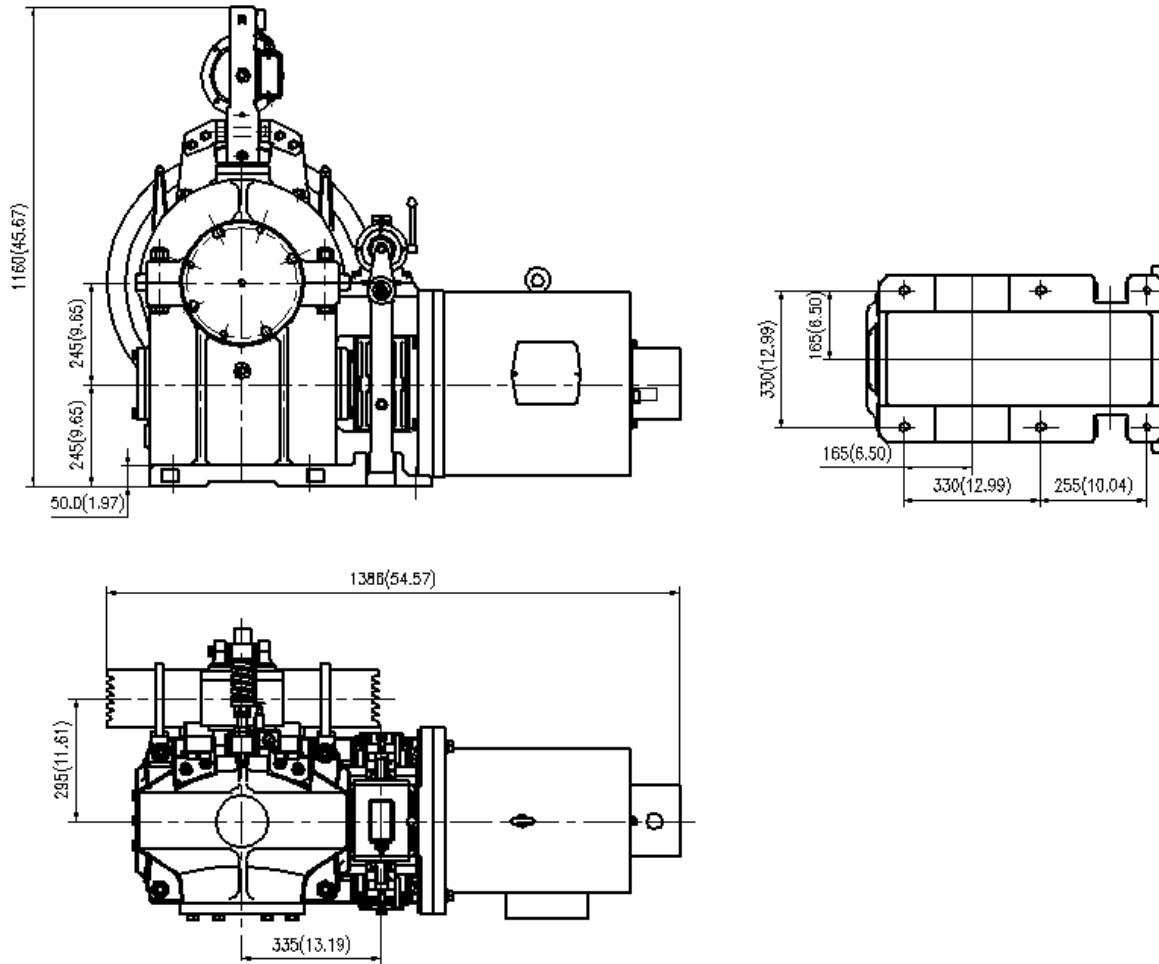

Torin Drive International
 7598 A E Beaty Drive suite 102
 Memphis, TN 38133, USA
 Phone: 901-290-1600
 Fax: 901-290-1680
 E-mail: Info@torindriveintl.com