

TGD3B

Geared Machine

Complete Operation and Service Manual

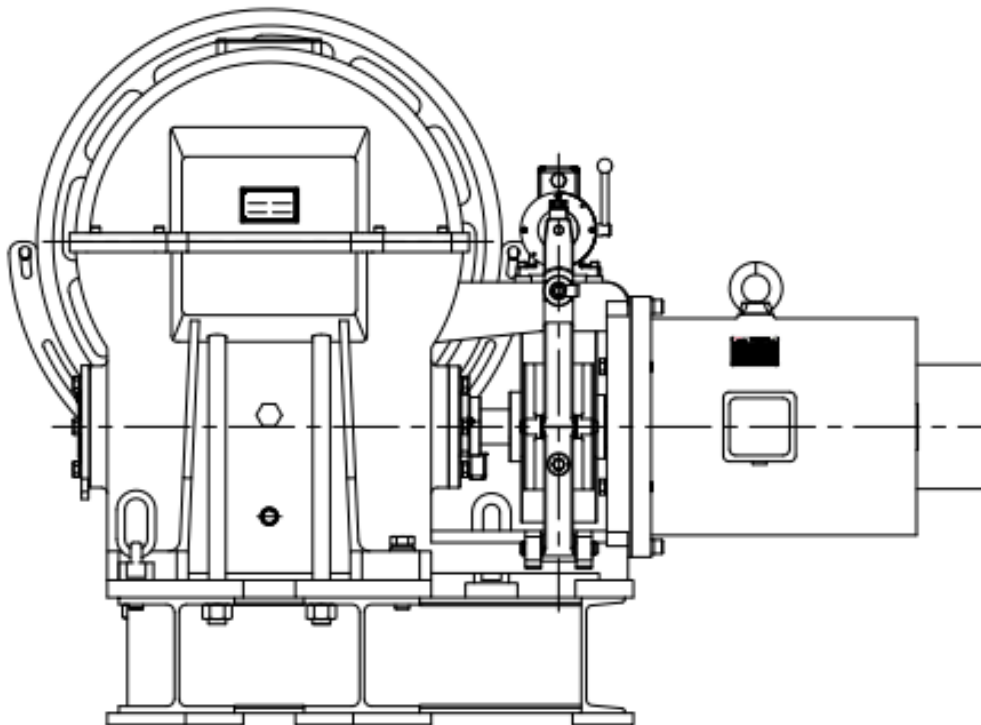

Contents

1.0 Application	5
1.1 Overview	5
1.2 Codes and Standards.....	5
1.3 Environmental Specifications.....	5
1.4 Specifications	5
2.0 Machine Component Overview	7
2.1 Machine Assembly	7
2.2 Brake Assembly.....	7
3.0 Safety Precautions	8
3.1 Terms in This Manual.....	8
3.2 General Safety	8
3.3 Electrical Safety.....	8
3.4 Electrical Hazards.....	8
3.5 Mainline Disconnect.....	8
3.6 Test Equipment Safety.....	9
3.7 When Power Is On.....	9
3.8 Product Specific Warnings.....	9
4.0 Arrival of the Equipment	10
4.1 Receiving	10
4.2 Storing	10
4.3 Hoisting	10
5.0 Installation	12
5.1 Motor Connection.....	12
5.2 Brake Connection	12
5.3 Absolute Encoder Connection	12
6.0 Maintenance	14
6.1 Brake Stroke Check	14
6.2 Brake Lining Wear Check.....	14
6.3 Lubricating Check	15
7.0 Adjustments	17
7.1 Brake Torque Adjustment	17
7.2 Brake Stroke Adjustment.....	19
7.3 Brake Synchronous Adjustment	21
8.0 Replacement	22
8.1 Encoder Replacement.....	22
8.1.1 Encoder removal instructions	22
8.1.2 Encoder mounting instructions	23
8.2 Brake Switch Replacement.....	23
8.2.1 Brake Switch removal instructions	23
8.2.2 Brake Switch mounting instructions.....	24
8.2.3 Brake switch adjustment.....	24
8.3 Motor Replacement	25
8.3.1 Motor removal instructions.....	25
8.3.2 Motor installation instructions.....	26
8.4 Brake Replacement.....	26
8.4.1 Brake removal instructions	26
8.4.2 Brake installation instructions	27
8.5 Brake Lining Replacement	28
8.5.1 Brake Lining removal instructions	28
8.5.2 Brake Lining installation instructions.....	29
8.6 Sheave replacement	29
8.6.1 Sheave removal instructions	29
8.6.2 Sheave installation instructions	34
8.7 Ring Gear Replacement.....	39

8.7.1 Ring Gear removal instructions	39
8.7.2 Ring Gear installation instructions	40
8.7.3 Backlash Adjustment	41
8.8 Bearing Replacement.....	44
8.8.1 Output shaft bearing removal	44
8.8.2 Worm Shaft Bearing Replacement.....	48
8.9 O-Rings and Seal Replacement	51
8.9.1 Output shaft O-ring and seal replacement instructions.....	51
8.9.1.1 If the oil leak happened at the bearing cover2 inside:.....	51
8.9.1.2 If the oil leak happened at the bearing cover2 outside:.....	51
8.9.2 Worm shaft O-ring and seal replacement.....	52
8.9.2.1 If the oil leak happened at the worm shaft back cover:	512
8.9.2.2 If the oil leak happened at the worm shaft through cover inside:	51
8.9.2.3 If the oil leak happened at the worm shaft through cover outside:	513
9.0 Troubleshooting chart.....	54
10.0 Traction Machine Assembly	555
11.0 Induction Motors & Encoders.....	59
12.0 Brake Assembly.....	60
13.0 MECHANICAL DIMENSIONS	611

IMPORTANT LIMITED LIABILITY AND WARRANTY NOTICE -
PLEASE READ:
REVISED AND EFFECTIVE SEPTEMBER 1, 2014

- **Express Limited Warranty - What is Covered:**

Effective September 1, 2014, Torin Drive International, LLC ("TDI") expressly warrants that the machines it sells to you will be free from defects in material and workmanship for a period of 12 months from the date of delivery. This express limited warranty is in lieu of all other warranties or conditions, express or implied (statutory or otherwise), verbal or written.

- **Express Limited Warranty - What is Not Covered:**

This express limited warranty does not cover defects, failures, or conditions in the machines sold to you by TDI that are due to normal wear and tear; abuse; misuse; misapplication; improper installation; improper modification/adjustment/repair; inadequate maintenance; failure to follow the machine's use and safety instructions; or any other contributing factors unrelated to the machine's material and workmanship.

- **All Implied Warranties Disclaimed to the Fullest Extent Allowed by Applicable Law:**

TDI's express limited warranty is in lieu of all other warranties or conditions, express or implied (statutory or otherwise), verbal or written. To the fullest extent allowed by applicable law, TDI EXPLICITLY DISCLAIMS ALL IMPLIED WARRANTIES OR CONDITIONS, INCLUDING BUT NOT LIMITED TO THE IMPLIED WARRANTY OF FITNESS FOR A PARTICULAR PURPOSE AND THE IMPLIED WARRANTY OF MERCHANTABILITY.

- **TDI Disclaims All Consequential Damages Relating to Its Express Limited Warranty:**

With the exception of the express limited warranty described above, to the fullest extent allowed by applicable law, TDI disclaims, and shall not be liable for direct, indirect, proximate, incidental, economic, and/or consequential damages relating in any way to the installation, use, maintenance, and operation of the machines it sells to you. Specifically, TDI shall not be liable for property damage; loss of profits; labor costs; downtime; legal costs; or any other damages measurable in money that arise from or relate in any way to the installation, use, maintenance, and operation of the machines it sells to you. This disclaimer and exclusion of consequential damages shall apply even if the express warranty fails of its essential purpose.

TDI's liability shall be limited to the terms of this express limited warranty. TDI's Limitation of Liability also applies to any pre-sale consulting with you (including any preliminary technical data consultations or reports); any post-sale consulting with you; and any effort by TDI to repair the machines it sells to you pursuant to this express limited warranty. With the exception of the express limited warranty described above, you assume all risks associated with the machines that TDI sells to you. The implied warranty disclaimer and the liability disclaimer above are made to the fullest extent allowed by applicable law. In the event that some provision(s) of the above implied warranty disclaimer and/or the liability disclaimer are not permitted under applicable law, then all other provisions shall remain in full force and effect to the fullest extent permitted under applicable law.

- **No Other Express or Implied Warranty Applies:**

The express limited warranty described above is the sole and exclusive warranty, express or implied (statutory or otherwise), for the machines that TDI sells to you. No employee, agent, or representative of TDI is authorized to alter, modify, expand, or reduce the terms of TDI's express limited warranty or to make any other warranty on behalf of TDI.

- **Express Limited Warranty - How to Redeem:**

To obtain the benefit of TDI's express limited warranty, please contact Warranty Claim Department, TDI International, 7598 A E Beaty Drive, Suite 102, Bartlett, TN 38133 as soon as possible after a defect in the machine's material or workmanship has been discovered. Please note: you must contact TDI concerning a machine covered by this express limited warranty before you attempt any repair work. Any unauthorized disassembly, repair, or reassembling performed by you will void TDI's responsibilities under this express limited warranty.

- **Express Limited Warranty - What TDI Will Do:**

Machines that are covered by this express limited warranty will be repaired or replaced, at TDI's option, during the warranty period. TDI will cover the expenses relating to the repair or replacement of its machines under this express limited warranty. However, TDI shall not be liable for direct, indirect, proximate, incidental, economic, and/or consequential damages relating in any way to efforts by TDI to repair or replace the machines it sells to you pursuant to this express limited warranty. Specifically, TDI shall not be liable for property damage; loss of profits; labor costs; downtime; legal costs; or any other damages measurable in money that arise from or relate in any way to TDI's efforts to repair or replace the machines it sells to you pursuant to this express limited warranty. If, after two (2) attempts at repair or replacement during the warranty period, the machine defect in material or workmanship persists, then you may elect to receive a refund of your original purchase price for the machine.

(Revised Full/PDF Doc Version of Express Limited Warranty)

1.0 Application

1.1 Overview

The TGD3B Machine is a geared machine designed for elevators. Its worm and gear configuration allows speeds up to 500 fpm (maximum), and an elevator capacity of up to 6000 lbs. 1:1, and 12000 lbs. 2:1 maximum.

The TGD3B machine used a drum brake with dual brake solenoids. The qualified elevator personnel can adjust the length of the spring to control the brake torque.

1.2 Codes and Standards

These machines are designed to comply with ASME A17.1-2005 code. The motors are designed with insulation class F minimum and have been approved and labeled by CSA.

1.3 Environmental Specifications

Operating ambient temperature: 0°C to 50°C

Storage temperature: 0°C to 60°C

Humidity: relative humidity of 10% to 95% non-condensing

Altitude: Up to 1000m above sea level without de-rating

1.4 Specifications

Induction motors: 480V / 60Hz / 4-poles / 3-phase

Brake coils: 200VDC/4A pick and 2A hold

Maximum full load mass: 30000 lbs.

Demountable bronze gear

Sheave diameter: 27.56/31.50 inches

Up to 8 x 0.625 in. Ropes

Designed for 180 starts per hour at 40% elevator duty cycle and 1:1 roping

Incremental encoder: 2048 pulse per revolution

Estimated weight: 3906 lbs.

Lubricating oil: 15L (3.9 gal)

Recommended oil is Shell Omala 460 or equivalent elevator gear oil.

Normal Brake Model: DZE-13E

Pick/Hold Voltage: 200/118 VDC

Pick/Hold Current: 4.00/2.36A

Resistance: 50 Ohms

Table 1 Machine Duty Table

Geared Machines For Single Wrap Applications				
Model Number		TGD3B-3545-HV-R	TGD3B-3550-HV-R	TGD3B-5020-HV-R
Motor Rating	Hp	50	50	35
Elevator Capacity	lbs	3500	3500	5000
Elevator Speed	fpm	450	500	200
Sheave Diameter	inches	31.5	31.5	27.56
Gear Ratio		61:2	82:3	61:1
Motor Use Speed	Rpm	1665	1657	1691
Motor Rate Current	A	55	55	40
Cwt	%	40	40	40
Geared Machines For Single Wrap Applications				
Model Number		TGD3B-6020-HV-R	TGD3B-4535-HV-R	TGD3B-6035-HV-R
Motor Rating	Hp	40	50	60
Elevator Capacity	lbs	6000	4500	6000
Elevator Speed	fpm	200	350	350
Sheave Diameter	inches	27.56	27.56	27.56
Gear Ratio		61:1	69:2	69:2
Motor Use Speed	Rpm	1691	1674	1674
Motor Rate Current	A	45	55	66A
wt	%	40	40	40
Geared Machines For Single Wrap Applications				
Model Number		TGD3B-4540-HV-R	TGD3B-4545-HV-R	TGD3B-6045-HV-R
Motor Rating	Hp	50	60	60
Elevator Capacity	lbs	4500	4500	6000
Elevator Speed	fpm	400	450	450
Sheave Diameter	inches	27.56	31.5	31.5
Gear Ratio		61:2	61:2	61:2
Motor Use Speed	Rpm	1691	1665	1665
Motor Rate Current	A	55	66	66
Cwt	%	40	40	45

2.0 Machine Component Overview

2.1 Machine Assembly

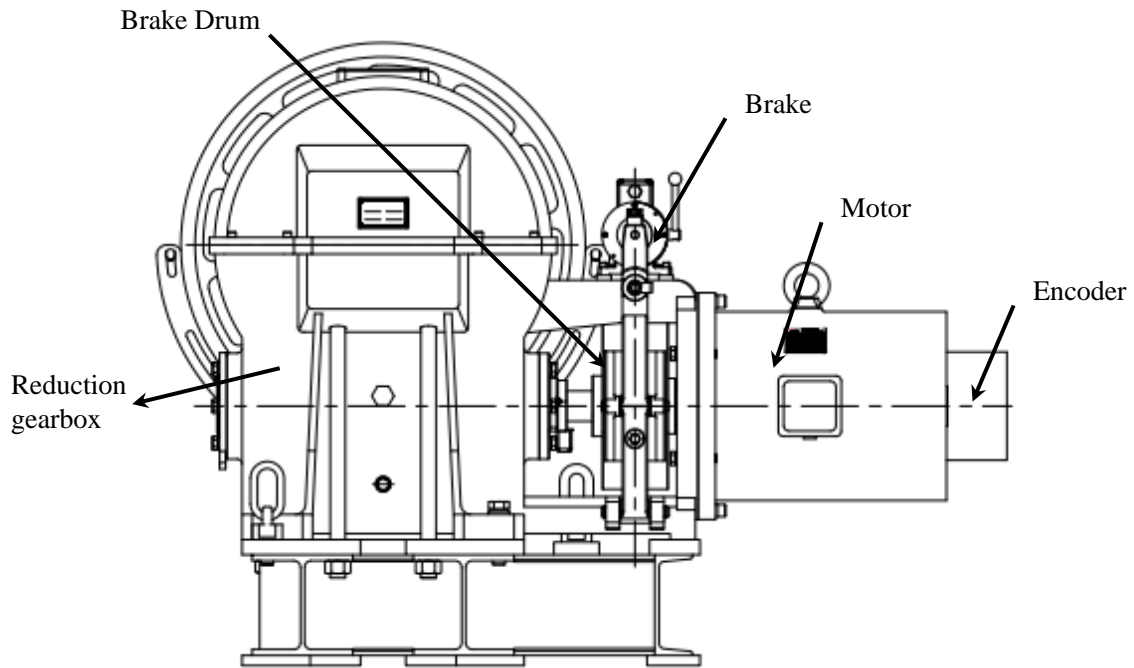

Figure 1 TGD3B Machine Assembly

2.2 Brake Assembly

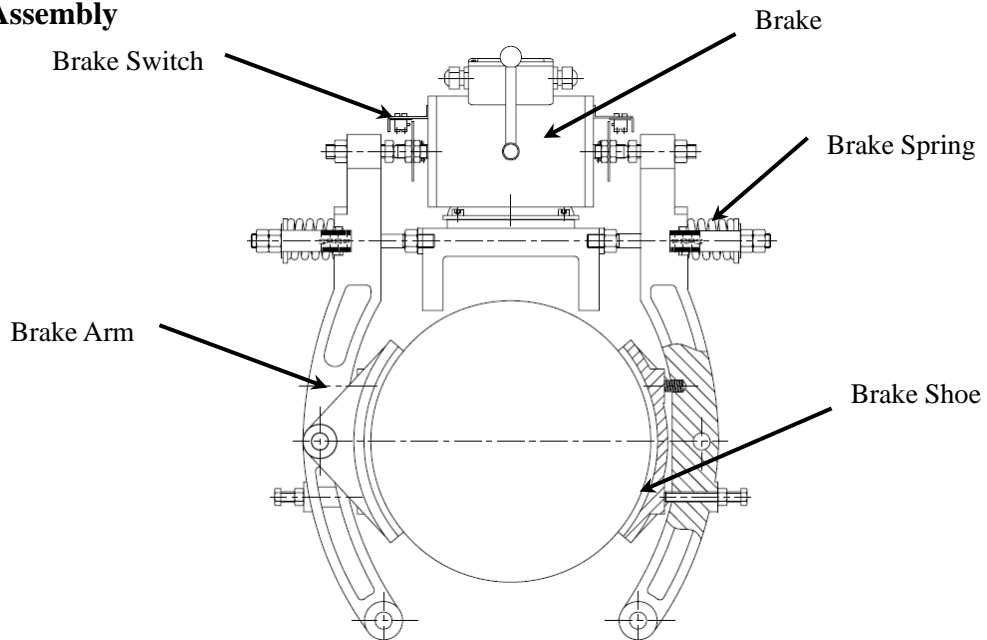

Figure 2 Brake Assembly

3.0 Safety Precautions

Important! Read this page BEFORE any work is performed on Elevator Equipment.

The procedures contained in this manual are intended for the use of qualified elevator personnel. In the interest of your personal safety and the safety of others, do NOT attempt ANY procedure that you are NOT qualified to perform. Always follow your company and OSHA required safety procedures and policies when performing ANY tasks.

All procedures must be done in accordance with the applicable rules in the latest edition of the National Electrical Code, the latest edition of ASME A17.1, and any governing local codes.

3.1 Terms in This Manual



CAUTION statements identify conditions that could result in damage to the equipment or other property if improper procedures are followed.



WARNING statements identify conditions that could result in personal injury if improper procedures are followed.

3.2 General Safety

Specific warnings and cautions are found where they apply, and DO NOT appear in this summary.

3.3 Electrical Safety

All wiring must be in accordance with the National Electrical Code, and must be consistent with all state and local codes.

3.4 Electrical Hazards

Electric shocks can cause personal injury or loss of life. Circuit breakers, switches and fuses may NOT disconnect all power to the equipment. Always refer to the wiring diagrams. Whether the AC supply is grounded or not, high voltage will be present at many points.

3.5 Mainline Disconnect

Unless otherwise suggested, always turn OFF, Lock and Tag out the mainline disconnect to remove power from the equipment.

3.6 Test Equipment Safety

Always refer to manufacturers' instruction book for proper test equipment operation and adjustments.

Meggering or buzzer type continuity testers can damage electronic components. Connection of devices such as voltmeters on certain low level analog circuits may degrade electronic system performance. Always use a voltmeter with a minimum impedance of 1M Ohm/Volt. A digital voltmeter is recommended.

3.7 When Power Is On

Dangerous voltages exist at several points in some products. To avoid personal injury, do **NOT** touch exposed electrical connections or components while power is **ON**.

3.8 Product Specific Warnings



The TGD3B Machine **MUST** be balanced during hoisting. See Hoisting Methods in the Installation section for proper lifting procedures.



Hang the elevator car before removing **ANY** bolts. Failure to do so may result in severe injury and equipment damage.

4.0 Arrival of the Equipment

4.1 Receiving

Upon arrival of the machine, make a visual check for any external damage immediately upon their arrival on site. If any damage incurred in transit is found, make a notice of claim in the presence of the forwarder. If necessary, do not put these machines into operation.

4.2 Storing

During storage in a warehouse or on the elevator job site, precautions should be taken to protect the machine from dust, dirt, moisture, and temperature extremes.

4.3 Hoisting

TGD3B machines can be lifted by using a combination of hooks, chains & slings designed to safely carry the weight of the machine. See Figure 3.

Note: Tighten all eye bolts before hoisting machine, motor or gear box, and always use properly rated hoisting equipment with certified rigging personal on-site. Inspect all equipment/tools being used before every task.

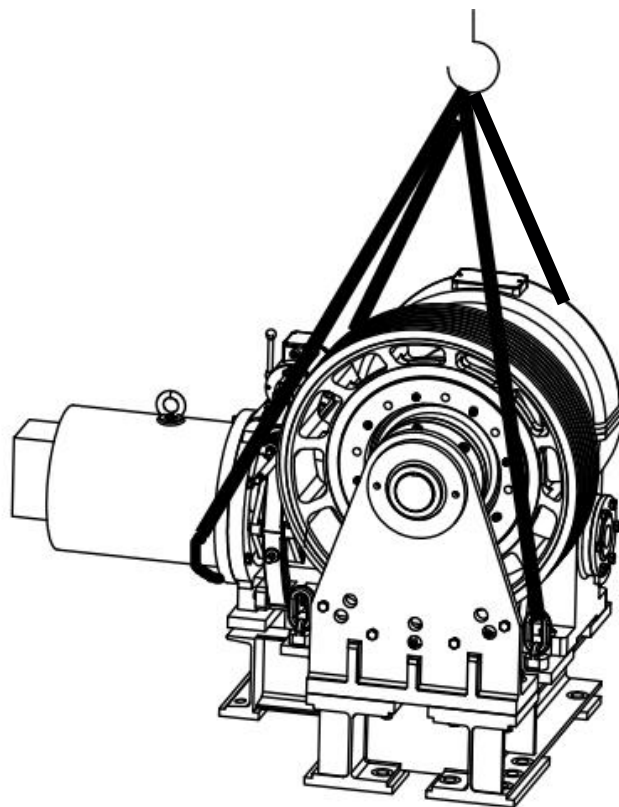

Figure 3 TGD3B Machine Recommended Hoisting Method

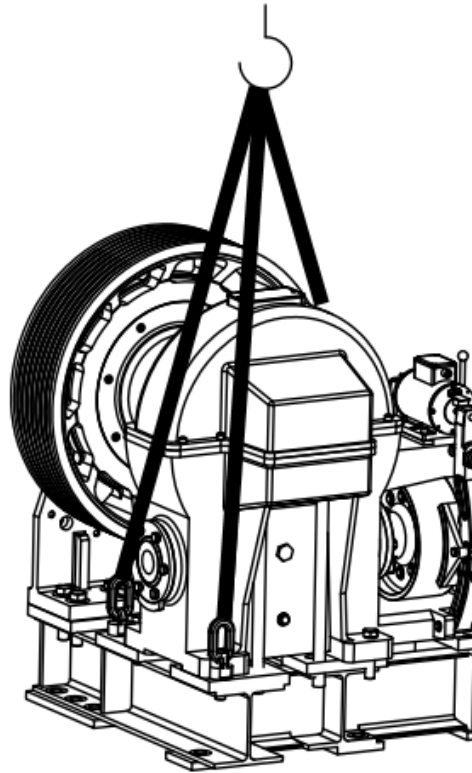

Figure 4 TGD3B Machine Recommended Hoisting Method without Motor

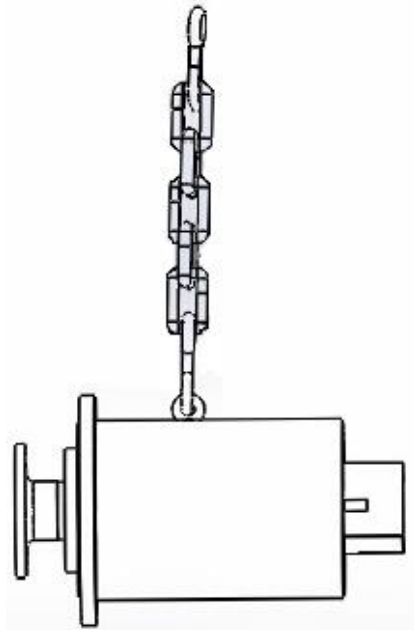

Figure 5 TGD3B Recommended Motor Lifting Method

5.0 Installation

5.1 Motor Connection

Use the job wiring diagrams with the motor configuration information to connect the motor to the controller.

Inverter drive output reactor: it is strongly recommended that a reactor to be installed between the inverter and motor to filter out high transient peak voltages that may damage the motor windings.



Before operating the machine, refer to the appropriate Product Manual and verify that the drive parameters for the job are set correctly.

Motor Connection

Connect the motor cable (U, V, W, and ground) to three phase AC reactor then to frequency inverter output terminal, and check the short-circuiting between the windings and the ground before connection.

Note: Connections P1 and P2 are motor thermal overload connections if needed.

5.2 Brake Connection

The power terminal of brake is BK+ (positive pole), BK-(negative pole).

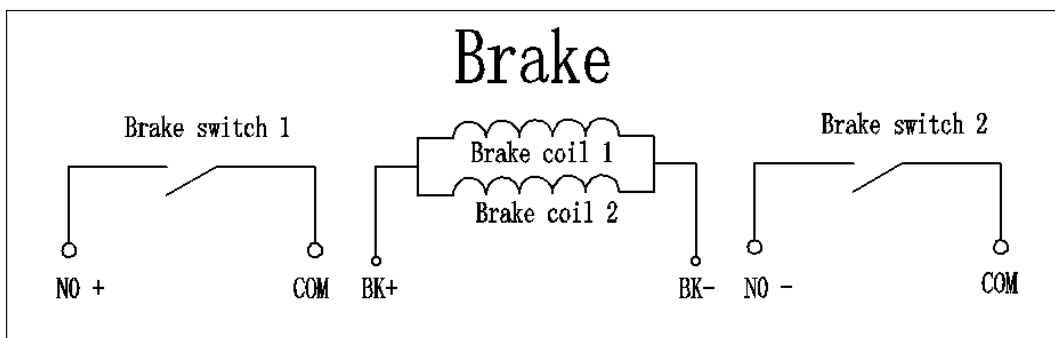

Figure 6 TGD3B Brake Wiring

There are two microswitches installed in the brake that are used to feed back the action of the brake. User can connect it according to your control system requests.

5.3 Absolute Encoder Connection

These machines are supplied with absolute encoder HS35 Incremental Optical Encoder. The incremental resolution is 2048 pulses per revolution. The absolute encoder is rear mounted for TGD3B machines. The operating personnel can connect the encoder and the inverter with special cable, and follow the below figure showing the signals. A 5VDC power supply is recommended.



Figure 7 Encoder Terminal Block

Note: machine is ready to run.

6.0 Maintenance



Only qualified personnel are allowed to perform any maintenance work. The person who performs the maintenance work must be very careful because some work must be performed when the machine is running. Always make sure the elevator is safely under control before attempting any of the following procedures.

6.1 Brake Stroke Check



Please pay attention to the value of brake stroke during the course of routine maintenance. If the brake stroke is too short, the power of the solenoid cannot push the brake arm to obtain enough gap, which will result in a disabled brake. Generally, the brake stroke has been adjusted in the factory and does not need to be adjusted in the field.

Suggest check cycle

- 3 months after initial install
- 6 months after initial install
- Annually for the remaining life of the product

Benchmark Criteria

The gap which is at the bottom of the Normal Brake Shoe and the drum should be 0.1~0.5mm (0.004”~0.02”).

6.2 Brake Lining Wear Check



If the brake lining wears too much, the brake will be disabled.

Suggest check cycle

- Annually after initial install

Benchmark Criteria

New Normal brake lining thickness is 8mm.

The Normal brake lining wear must be <2mm (0.079”). Use steel ruler to measure the thickness of the brake shoe, the thickness must be >6mm (0.236”). Otherwise replace the brake lining or replace the whole brake assembly. See Figure 8.

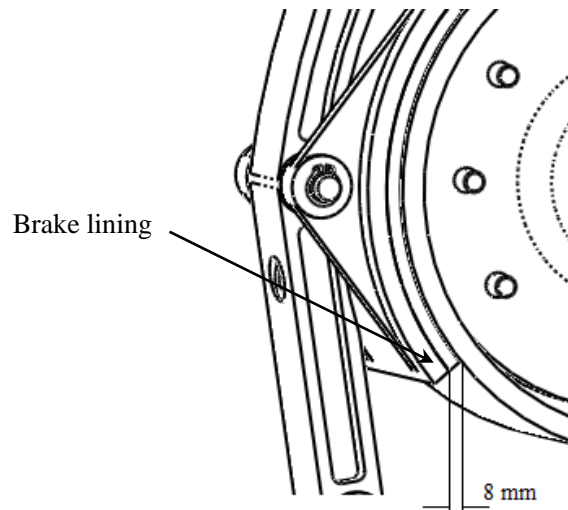

**Figure 8 Normal brake lining
Showing initial thickness**

6.3 Lubricating Check

The oil type we recommend is Shell Omala 460 or equivalent elevator gear oil.

Note: Do not use synthetic oil!



Whether the gear oil needs to be changed depends on the cleanliness and ageing degree. Check the oil color, smell and degree of cleanliness to determine whether oil needs to be changed. If oil turns black and smells foul, it should be changed. Use filter paper to check hot oil and watch for metal shavings to confirm whether oil needs changing. The oil volume of the TGD3B machine is about 15L (3.9 gal). The oil level should be at scale mark (red dot). If too little, the lubrication will be not enough. If too much, the oil will leak out.

If the machine is in storage more than 1 year, the oil should be changed before use.

Suggest check cycle

Using conventional oil, the first oil change should be done after the new machine runs **400 hours**.

After that, depending on the machine running condition, change conventional oil each 2000-3000 hours (at most 12-18 months).

For oil change it is not necessary to hang the car and remove the ropes.

Required Tools & Materials:

Open end Wrench: 16mm & 22mm

Funnel & Oil pan

Oil change procedure

1. Remove elevator from service and verify the elevator is under your control.
2. Take off top cover with 16mm wrench for air flow.
3. Place funnel and oil pan right next to the oil drain.
4. Remove oil plug, drain the old oil away.
5. When the oil has ceased running out of the geared box, hand tighten oil plug to make sure it is not being cross-threaded; tighten the rest of the way with the 22mm wrench.
6. Pour in 15 L (3.9gal) conventional oil into the gear box top cover.
7. Run the car floor to floor for 10 minutes and check the machine running situation. Also check the gear box for any signs of heat or smoke, while verifying the proper disbursement of oil over the ring gear.

7.0 Adjustments

7.1 Brake Torque Adjustment



Generally, the brake stroke has been adjusted in the factory and does not need to be re-adjusted any more. Brake torque adjustment may be required if the brake fails the 125% load test. Proper brake operations with regard to loading **MUST** be verified before anyone is allowed to ride on the platform.

Preparation

1. Verify that any required Compensation Chains or Rope Assemblies have been installed.
2. On construction jobs, verify that hoist way barricades are in place to prevent unauthorized access.

Required Tools & Materials:

Open end wrench: 24mm (x2)

Torque wrench

12 point 22mm socket

Loctite 243

Adjustment Procedure Steps

1. Check the length of the spring's decrement, which is showed on the surveyor's rod. The surveyor's rod should show the following compress distance length: See Table 2, otherwise the length must be readjusted.
2. Park the counterweight on the buffers and remove the elevator from service.

Table 2 Brake Spring Length Decrement

Motor Power	Compress distance
≤35Hp	7-9mm
≤40Hp	11-13mm
≤60Hp	13-15mm

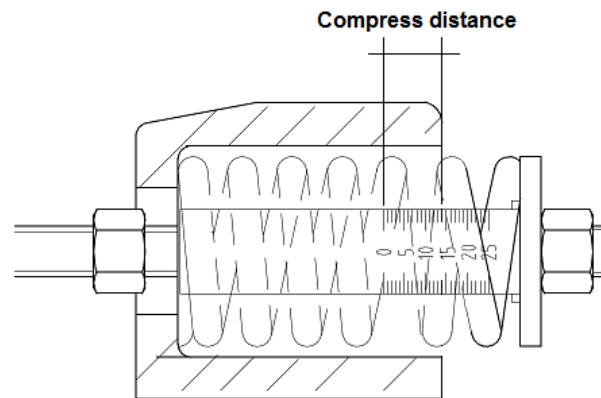

Figure 9 Brake Spring Length Decrement

3. Loosen the Spring Adjustment Locknut by open end wrench (24mm), then adjust the Spring Adjustment Washer slowly to ensure the decrement is in range.

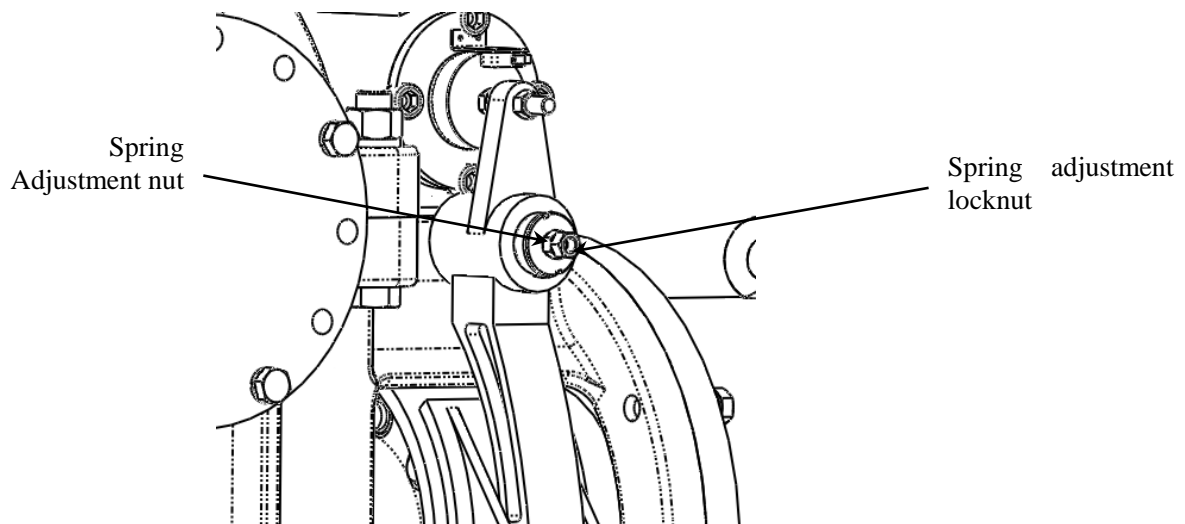

Figure 10 Brake Spring Adjustment

4. If the compress distance is too big, loosen the spring adjustment nut counterclockwise to reduce it. If the length is too small, tighten the spring adjustment nut clockwise to increase the length.
5. Re-measure and confirm that the dimension is correct and then tighten the spring adjustment locknut.

6. Also measure the brake torque with a torque wrench. First of all, remove the encoder cover from the motor shaft. With a 12 point, 22mm socket and torque wrench on the end of the motor shaft, measure the torque. See Figure 11. The torque should match the value in Table 3 below. For information regarding how to remove the encoder cover, refer to this manual Encoder Replacement, Section 8.1 Encoder removal.

Table 3 Brake Torque

Motor Power	Brake torque
≤35Hp	≥280Nm (206 ft-lb)
≤40Hp	≥395Nm (291 ft-lb)
≤60Hp	≥480Nm (354 ft-lb)

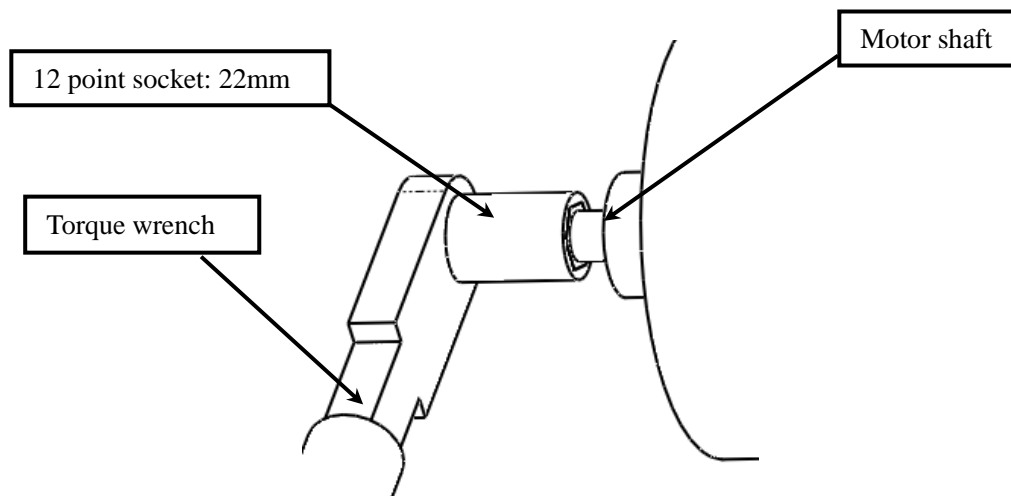
**Figure 11 Brake Torque Test**

7. Then apply red Loctite 243 between the Spring Adjustment Nut and locknut for anti-vibration purpose.

7.2 Brake Stroke Adjustment

WARNING! Generally, the brake stroke has been adjusted in the factory and does not need to be re-adjusted any more. Proper brake operations with regard to loading **MUST** be verified before anyone is allowed to ride on the platform.

Preparation

1. Verify that any required Compensation Chains or Rope Assemblies have been installed.
2. On construction jobs, verify that hoist way barricades are in place to prevent unauthorized access.

Required Tools & Materials:

Open End Wrench: 18mm

Hex wrench: 6mm

Feeler gauges: 0.1-0.5mm

Adjustment Procedure

If the brake stroke is too small, the brake drum and brake lining will rub, and the machine will make abnormal noise when it runs.

1. Loosen the Stroke adjustment locknut, verify that the Hit Cap and the Stroke Adjustment Bolt just contact when the brake's power is on, and screw the Stroke Adjustment Bolt into the direction of the brake solenoid to 1.6~2.0mm (0.063"~0.079"). See Figure 12.

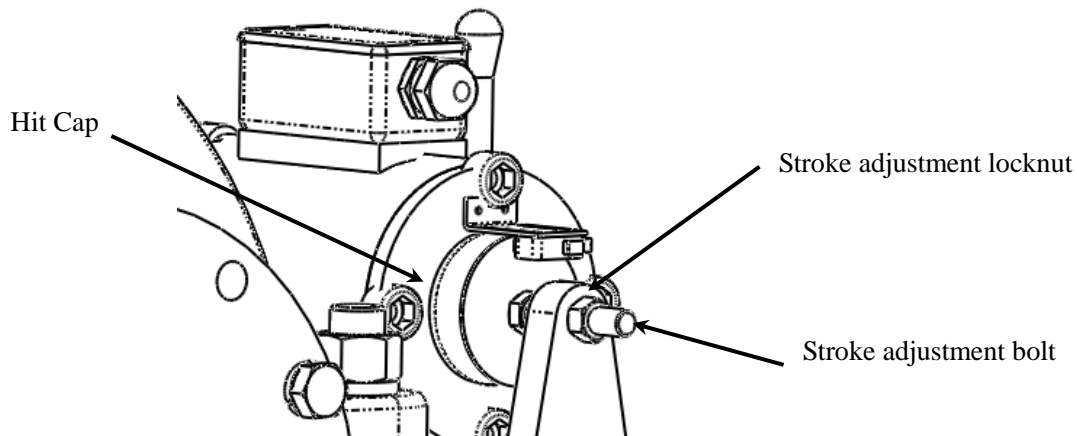

Figure 12 Brake Stroke Adjustment

2. Measure the gap at the bottom of the Brake Lining and the drum, verify it is 0.1-0.5 mm (0.004"~0.02") with feeler gauges, and make sure the gap is about uniform from top to bottom. If the gap on the top is too big, loosen locknut with open end wrench 18 mm and tighten the bolt clockwise with hex wrench 6mm to reduce it. If the gap is too small, loosen the bolt counter-clockwise to increase the gap. See Figure 13.

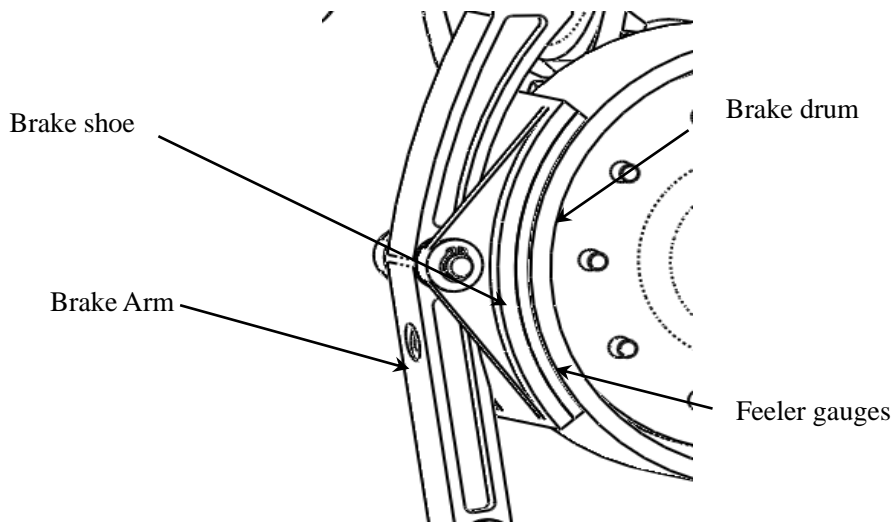

Figure 13 Brake gap

3. Tighten the Locknut M12 then apply red Loctite 243 between the locknut and the bolt.

7.3 Brake Synchronous Adjustment



This step should be done when the brake torque meets the specified value (See Table 3).

Adjustment Procedure

1. If a Brake Arm opens slower than the other arm, loosen the Synchronization locknut and bolt of slower arm or tighten the faster arm synchronization bolt after loosening its locknut, until both arms open and close at the same time.
2. Once both arms open and close at the same time, then tighten the locknuts.
3. After adjusting, verify the brake torque according to **Section 7.1 Brake Torque Adjustment**.

8.0 Replacement



The user who does the replacement must make sure that the machine is powered off and the elevator is secure and will not be moved unexpectedly.

Only qualified personnel are allowed to perform the replacement work.



Please refer to the troubleshooting procedure first and make sure that the component is actually bad before performing this replacement procedure.

8.1 Encoder Replacement

Required Tools & Materials:

Small flat head screw driver

Open end wrench (13mm)

Hex wrench: 9/64", 4mm, 6mm, 8mm

Clean cloth

New Encoder

8.1.1 Encoder removal instructions

1. Remove the encoder cover using the Hex wrench 6mm or open end wrench as appropriate.
2. Remove the encoder cable using a flat head screw driver.
3. Loosen the locking bolt of the encoder using a 9/64" hex wrench, and remove the bolt which connects the motor and the encoder bracket with a 8mm hex wrench, then remove the broken encoder. See Figure 14.

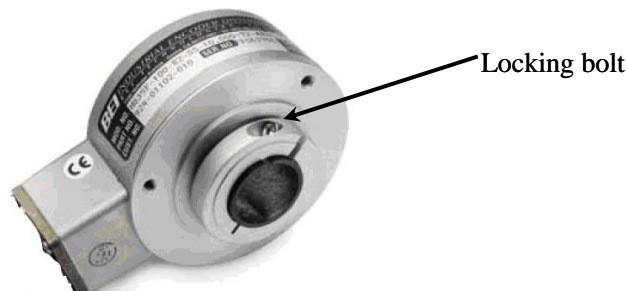

Figure 14 Encoder

8.1.2 Encoder mounting instructions

1. Attach the encoder bracket to the encoder so that the cable connection is near the opening in the encoder cover.
2. Check new encoder by slowly spinning it to check for smooth operation before installing.
2. Clean the motor shaft with clean cloth, then slip the encoder on to the shaft.
3. Tighten the bolt into the motor through the encoder bracket with a 8mm hex wrench and tighten the locking bolt with the 9/64" hex wrench.
4. Connect the encoder and the transducer cable, and install the encoder cover.

8.2 Brake Switch Replacement



Please refer to the troubleshooting procedure first and make sure that the switch is actually bad before performing this replacement procedure.

Required Tools & Materials:

Brake switch

Phillips screw driver

Small flat head screw driver

Loctite 290

Multimeter

Adjustable end wrench

Feeler gauges: 1mm

8.2.1 Brake Switch removal instructions

1. Loosen the bolts and the washers in the brake terminal box using the Phillips head screw driver, and remove the terminal box cover.
2. Remove the brake switch cable which needs to be replaced from the brake terminal using a small flat head screw driver.
3. Loosen the Composite slot screw M4x10 using a Phillips head screw driver, then remove the broken switch with bracket. See Figure 15.

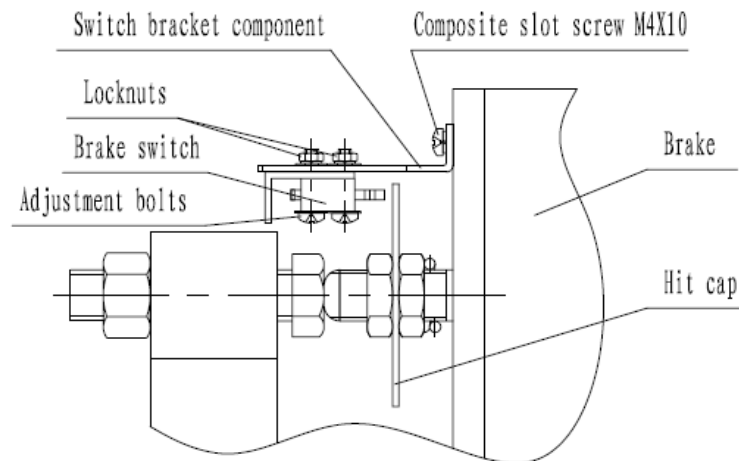

Figure 15 Brake Switch mounting

8.2.2 Brake Switch mounting instructions

1. Clean the switch bracket component mating surface if it is not clean.
2. Install the brake switch and the bracket component on the brake surface using the composite slot screw M4x10.
3. Reconnect the new brake switch cable.

8.2.3 Brake switch adjustment

1. Loosen the adjustment bolts using a Phillips head screw driver and adjustable end wrench, and adjust the position of the brake switch.
2. Place a 1mm feeler gauge between the Hit cap and the brake switch, and adjust the switch slowly. When the switch operates, tighten the adjustment bolts and locknut, and remove the feeler gauges.
3. Apply Loctite 290 between the screw heads and the switch body.

8.3 Motor Replacement



Please refer to the troubleshooting procedure first and make sure that the motor is actually bad before performing this replacement procedure.

Required Tools & Materials:

Hoisting equipment

Open end wrench: 24mm

Inner hexagon wrench (14mm)

Arm Puller

Clean cloth

Lubricating oil

Torque Wrench

8.3.1 Motor removal instructions

1. Remove the elevator from service.
2. Remove the encoder from the motor, refer to Section 8.1 Encoder Replacement.
3. Remove the power cable from the terminal box.
4. Install a hoist and rigging over the motor, and hoist the motor until pressure is applied to the rigging. See Figure 16.
5. Remove the Bolts (6) M16x60 and washers.

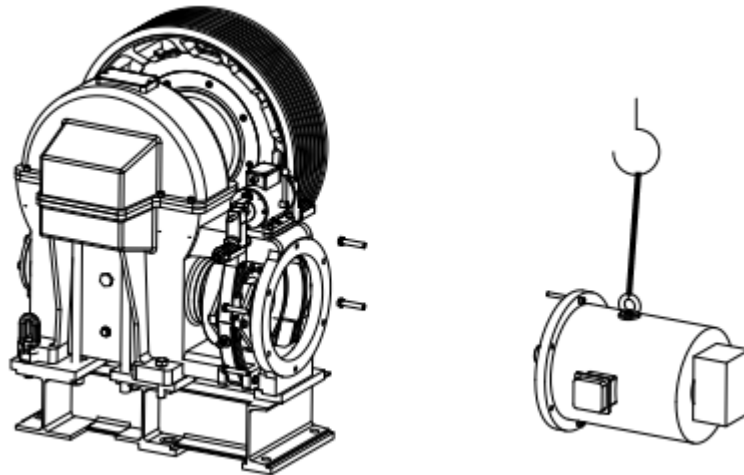

Figure 16 Motor Replacement

6. Move the motor away from the traction machine.
7. Place large blocks on the ground, below the motor, and lower the motor onto the blocks.
The blocks should be large enough to support the motor.

8.3.2 Motor installation instructions.

1. Clean the motor shaft with clean cloth, put the keyway onto the shaft and apply some lubricating oil.
2. Apply some lubricating oil on the flexible coupling, hoist the motor and keep level, **make the position of the motor coupling's keyway and the position of the brake drum's keyway opposite each other.** (Note: Mark the encoder end of the motor shaft in line with the key to make alignment easier.)
3. Tighten the bolts (6) M16x60 and washers to 125-150Nm (92 ft-lb-110 ft-lb).
4. Turn the motor and measure the radial travel movement of the brake pulley excircle is no more than 0.004”.

8.4 Brake Replacement



Please refer to the troubleshooting procedure first and make sure that the brake is actually bad before performing this replacement procedure.

Required Tools & Materials:

Hex Wrench (6mm)

Phillips screwdriver

Small flathead screwdriver

8.4.1 Brake removal instructions

1. Remove the elevator from the service.
2. Remove the brake cable and the brake switch cable from the brake terminal box.
3. Loosen the bolts (4) M8x20 and washers, and remove the broken brake from the gear box.
See Figure 17.

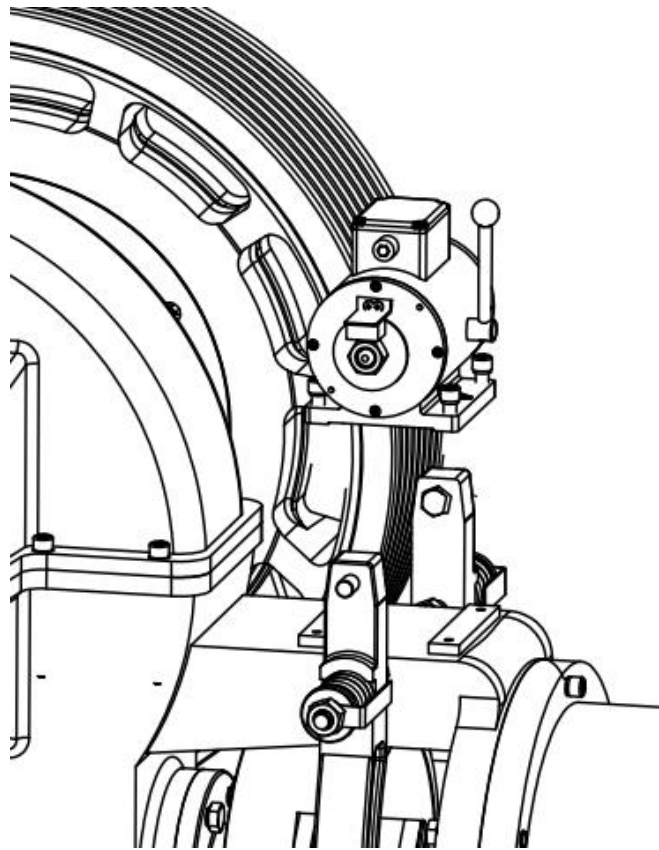

Figure 17 Brake Removal

8.4.2 Brake installation instructions

1. Install the new brake onto the gear box, and attach it with the bolts M8x20 and washers, but do not tighten. See Figure 18.
2. Adjust the position of the brake, making sure that the axis of the solenoid, the Spring Threaded Stud and the Stroke Adjustment Bolt are aligned in the same plane, and tighten the bolts M8x20, securing the position of the brake. See Figure 18.
3. For brake adjustment refer to this manual Section 7.0 Brake Adjustment and Section 8.2.3 Brake Switch Adjustment.

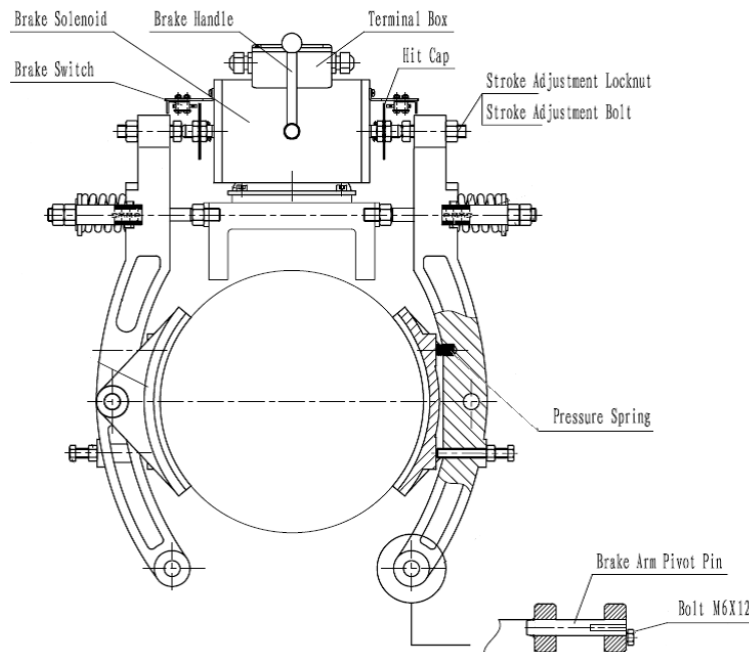

Figure 18 Brake Assembly

8.5 Brake Lining Replacement



WARNING! Please refer to the troubleshooting procedure first and make sure that the lining is actually bad before performing this replacement procedure.

If the brake lining wears more than 2mm, the brake lining or the whole brake arm assembly must be replaced.

Required Tools & Materials:

Open end wrench: 18mm, 24mm

Hammer

Snap ring pliers

M8x50 bolt

8.5.1 Brake Lining removal instructions

1. Remove the elevator from service and make sure the counterweight is landed on the buffer.
2. Remove the spring adjustment nut & washer taking the pressure off the brake spring.
3. Remove the two snap rings (one brake arm pivot pin has two snap rings).
4. Remove the brake arm pivot pin with a hammer.
5. Remove the spring adjustment nut, washer & brake spring.
6. Move the brake arm away from the machine.

NOTE: This brake arm is not heavy enough to require rigging and can be removed by hand.

7. Remove the snap rings on the pin holding the brake shoe to the brake arm. Then remove the pin with a hammer and a bolt M8x50. **Do not lose the pressure (bucking) spring!**
8. Remove the worn brake shoe and lining.

8.5.2 Brake Lining installation instructions

1. Clean the brake arm and new brake shoe and lining with clean cloth.
2. Install the pressure spring into the hole of the brake arm, and attach the brake shoe with the pin and the snap rings.
3. Install the brake arm assembly into the gear box with the brake arm pivot pin, and attach it with the snap rings.
4. Adjust the bolt M12x90 and the nut M12 in order so the brake lining makes good contact with the brake pulley.
5. Install the Spring Threaded Stud, Brake Spring, Spring Adjustment Nut, and Adjustment Washer.
6. For brake adjustment refer to Section 6.1 Brake Adjustment.

8.6 Sheave replacement



Please refer to the troubleshooting procedure first and make sure that the sheave is actually bad before performing this replacement procedure

Required Tools & Materials:

Hoisting equipment

Torque wrench: 520Nm (371 ft-lb)

Dial indicator

Open end wrench: 41mm, 30mm, 18mm

Claw wrench

Arm puller

Clean cloth

8.6.1 Sheave removal instructions

1. Remove the elevator from service, hang the elevator in the hoist way with the proper hoisting and rigging equipment. Add a rope block and then begin hoisting the car until you have enough slack in the ropes to remove them from the drive sheave.
2. Loosen the Nut M16, bolt M16X30 and washers on the guard by the open wrench (24mm), and remove the guard and guard holder. Remove the ropes. See Figure 19.

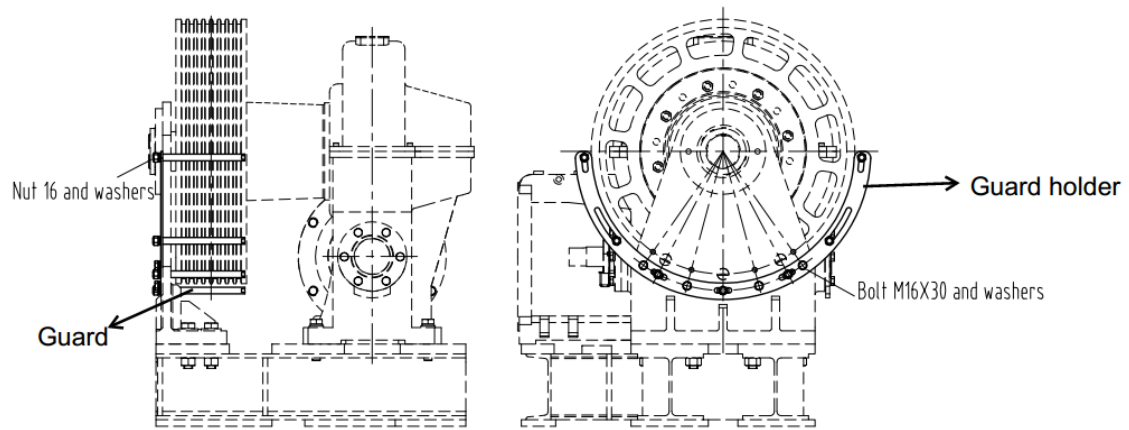

Figure 19 Guard removal

3. Remove the two Bolts M10X20 and then remove the Top Cover. See Figure 20.
4. Remove the eight Bolts M10X35 and then remove the top gear case. See Figure 21.

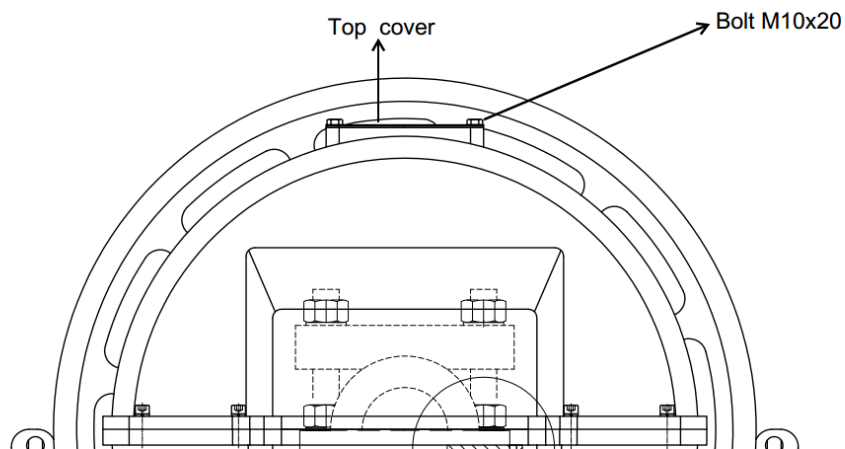

Figure 20 Remove top cover

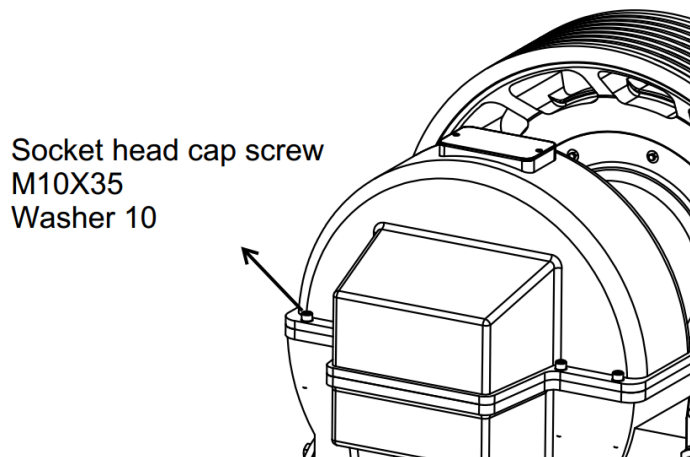

Figure 21 Hoisting the Gear case top

5. Remove the Pedestal Bolts M27x120, washer 27, and nut 27 using open end wrench 41mm. **Mark the Pedestal gasket (shim) location and number so they can be replaced in the same location and order.** See Figure 22.
6. Remove round nut M105x2 and washer 105 using Claw wrench. See figure 23.

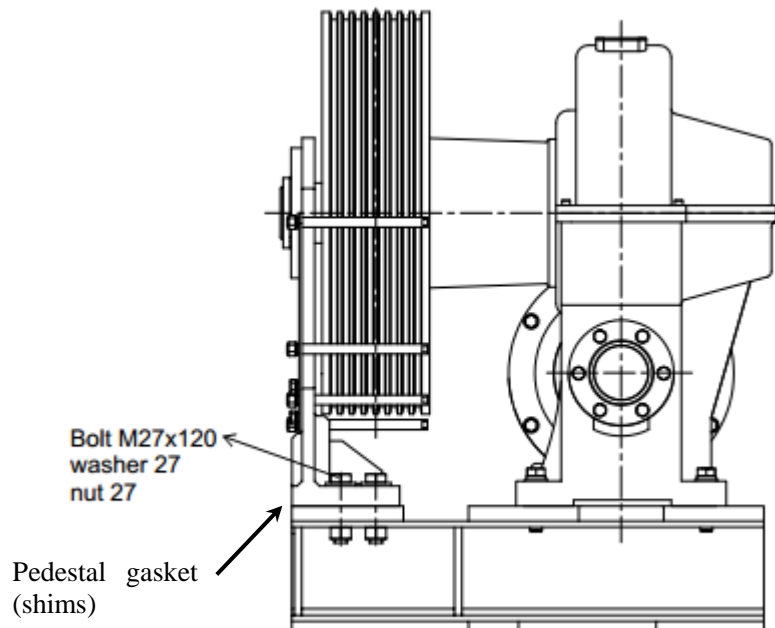

Figure 22 Remove the Pedestal bolts.

Note gasket (shim) location

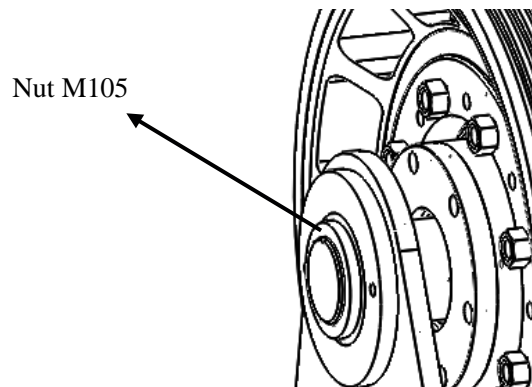

Figure 23 Remove the round nut M105.

7. Unscrew Bolts M24 and Nut 30. Remove the Pressure pad and shaft seat body. See Figure 24.

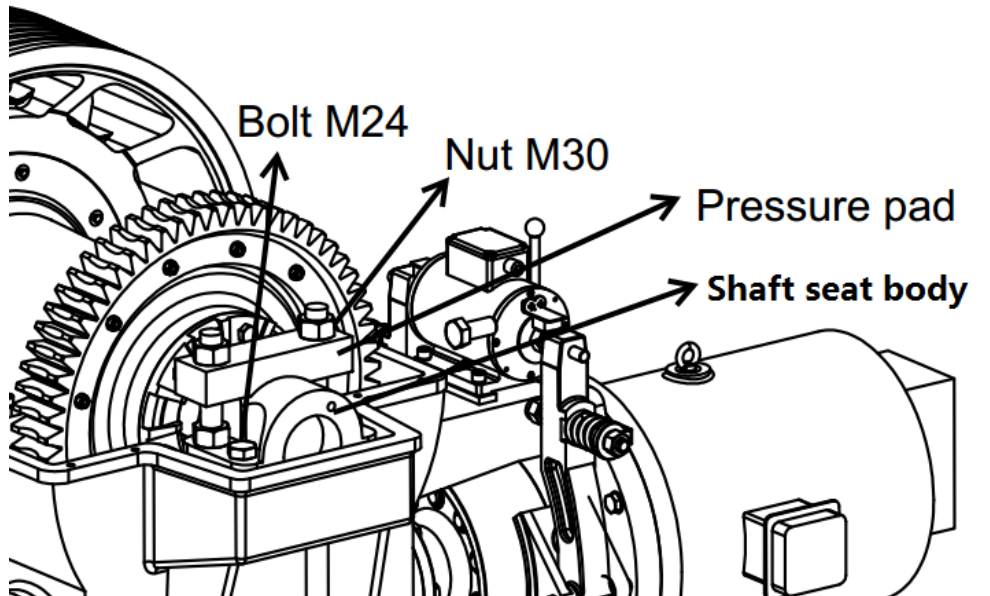

Figure 24 Remove the Support body.

8. Install hoisting and rigging over the sheave.
9. Slings the sheave (with the gear); clean the oil from the gear.
NOTE: The sheave (with the gear) must be able to move 320mm (12.75") above the gear case. See Figure 26.
10. Separate the main shaft and the Pedestal. See Figure 25.

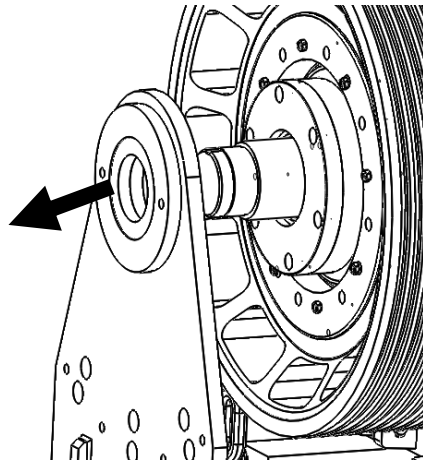

Figure 25 Separate Main shaft and the Pedestal



Figure 26 Sling the sheave and gear

11. Place two stands (approximately 100 x 230mm, 4" x 5.5") under the gear surface. See Figure 27.
12. Remove the eight bolts (M20x120), nuts (M20) and washers (20) with open end wrench (30mm).
13. Turn four bolts (M20x120) removed in Step 12 into threaded holes to push the sheave out of carrier. Then remove the four bolts (M20x120).

NOTE: When the four bolts (M20x120) contact the carrier, turn each equally to push the sheave from the carrier.

14. Install two Eye Screws (M20) into the threaded holes locations at opposite sides of the sheave.
15. Hoist the sheave away from the carrier.

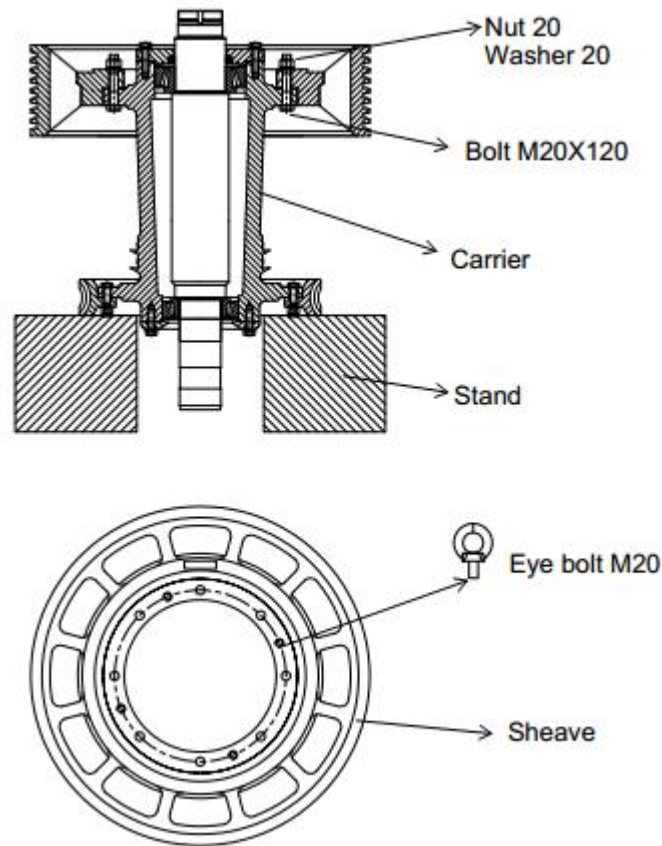

Figure 27 Hoist the sheave

8.6.2 Sheave installation instructions

1. Clean the carrier's mating surface with the sheave. Make sure there is no rust or dirty grease.
2. Install two Eye Screws (M20) into the threaded holes locations at opposite sides of the new sheave.
3. Place the sheave onto heating equipment, then gently heat the sheave to about $160\pm 20^{\circ}\text{C}$ ($320\pm 68^{\circ}\text{F}$).
4. Quickly slide the heated sheave fully onto the carrier. With a gloved hand ensure that the sheave is lined up with the holes in the carrier. (A drift pin or M20 bolt may be used.) See Figure 28.

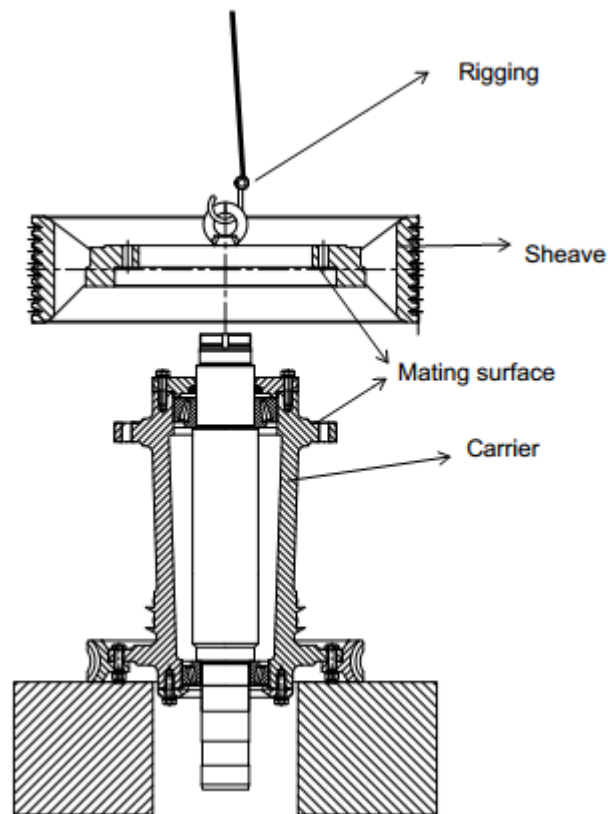

Figure 28 Sheave replacement

5. Allow the sheave to cool completely.
6. Insert, thread, and hand tighten the eight bolts (M20x120), nuts (M20) and Washers (20).
7. Using the torque wrench, tighten the eight bolts (M20x120) to 300Nm (214 ft-lb).
8. Lift the sheave (with the gear) into the gear case.
9. Fit main shaft, pedestal and pedestal gaskets (shims) together, then insert, thread, and hand tighten the bolts (M27x120), Washers (27), and nut 27; tighten round nut. **Make sure the pedestal gaskets are in the same location as when removed.** See figure 29.

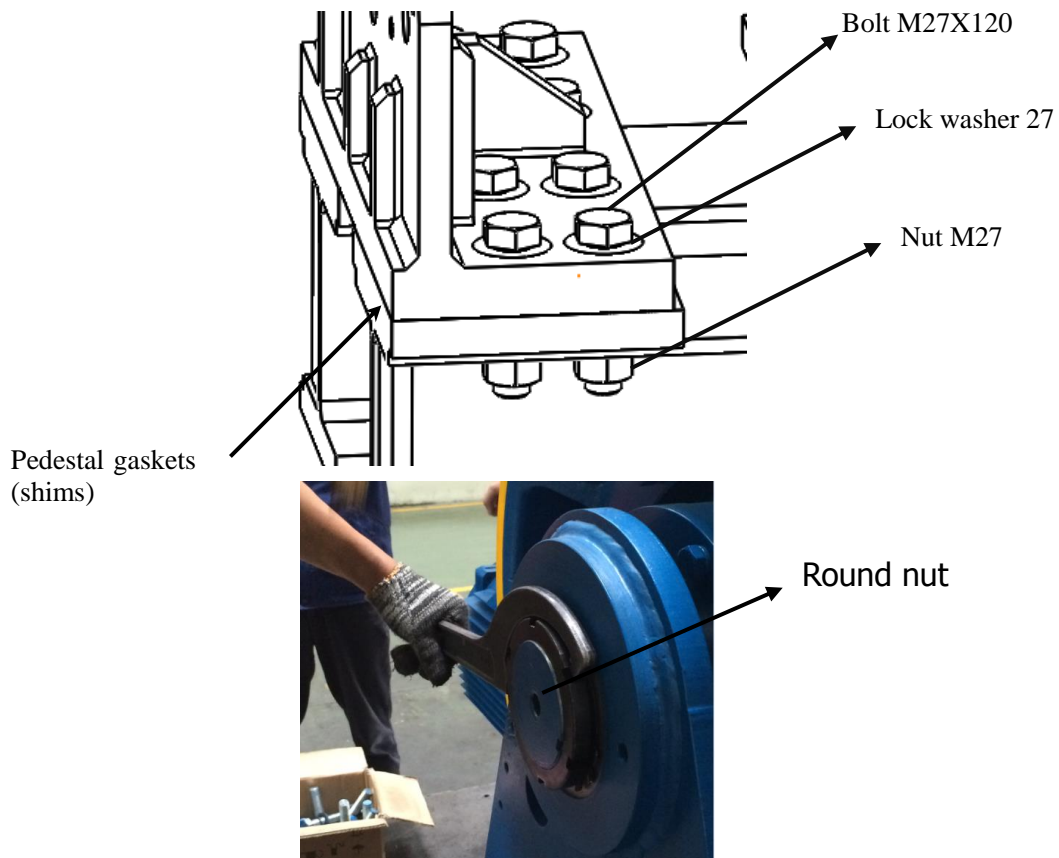

Figure 29 Sheave replacement

10. Insert, thread, and hand tighten the bolts (M24x120), Washers (24), nut 30 and pressure block. See Figure 24 (above).
11. Using the torque wrench, tighten the two bolts (M24x120) to 520Nm (371 ft-lb).
12. Clean the top gear case's mating surface and the gear case's mating surface. Make sure there is no rust or dirty grease.
13. Apply sealant on gear case's mating surface with the top gear case. See Figure 30.

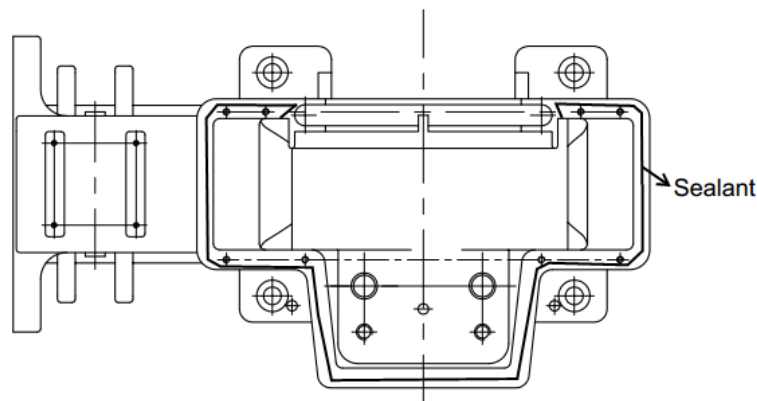

Figure 30 Adding sealant to the gear case

14. Install the top gear case onto the gear case.

15. Insert, thread, and hand tighten the four Bolts (M10x35) and Washer 10. See Figure 31.
16. Install the Top Cover using the two Bolts (M10x20) to attach it.

Socket head cap screw
M10X35
Washer 10

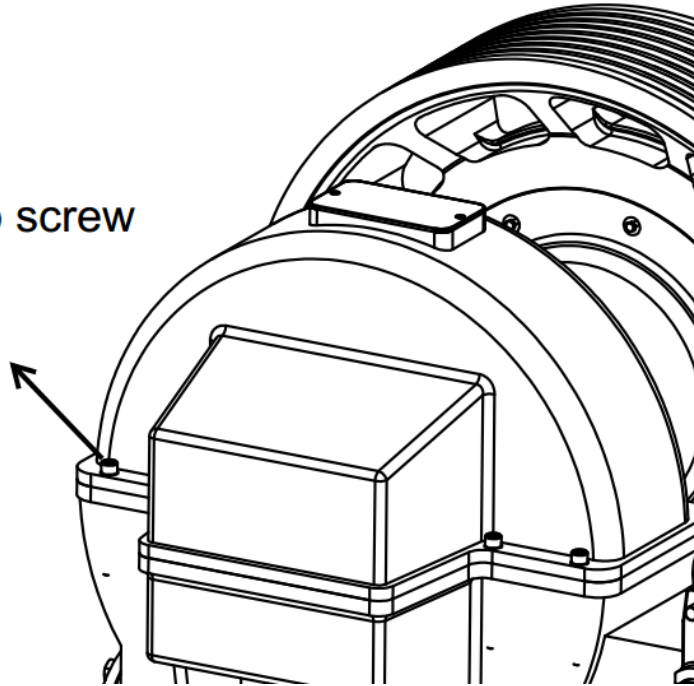

Figure 31 Reinstall top gear case

17. Clean the rope groove of the drive sheave-this will be used as an indicator surface.
18. Attach a dial indicator to the machine, over the drive sheave. Set the indicator to measure the side of the cleaned rope groove. See Figure 32.
19. Rotate the drive sheave until the least reading of the dial indicator. Set the dial indicator to “0”. This will become the reference point for adjusting the weave of the drive sheave.
20. With the dial indicator, check for TIR of $\leq 0.35\text{mm}$ (if the sheave is $\Phi 700\text{mm}$)/ 0.4mm (if the sheave is $\Phi 800\text{mm}$) by rotating the drive sheave clockwise one (1) complete revolution.
21. Tighten the M27x120 Pedestal bolts to 760Nm (560 ft-lb.)



Figure 32 Dial Indicator position

22. Reinstall the ropes.
23. Begin lowering the car until the ropes are holding and the hoisting equipment is no longer handling any load. Then remove the hoisting and rigging equipment securing the car.
24. Release the safety and governor.
25. Turn ON the mainline disconnect.
26. With the weight now on the drive sheave, run the car down and up a few landings.
27. Repeat the measurements in Steps 18-20 to ensure the weave of the drive sheave has not changed.
28. Reinstall the rope retainers.
29. Cycle the car and check for any signs of vibration and/or heat before releasing the elevator back to the public.

8.7 Ring Gear Replacement



Please refer to the troubleshooting procedure first and make sure that the component is actually bad before performing this replacement procedure.

Required Tools & Materials:

Box end wrench (24mm)

Reamer (16X230)

Hammer

Dial indicator

Color ink

Hoisting equipment

Clean cloth

Bolts (M16x60) (4)

8.7.1 Ring Gear removal instructions

1. Refer to Section 8.6.1 Sheave Replacement Sheave removal instructions, from step 1 to step 10.
2. Remove the oil drain bolt; drain the oil. Make sure the container can hold at least 15L (3.9 gallons) See Figure 33.
3. Tighten the oil drain bolt.



Figure 33 Oil Drain

4. Place two stands under the sheave surface. See Figure 34.
5. Remove the twelve bolts M16 and nuts using an open end wrench (24mm). **Note: These bolts may NOT be used in step 6!**
6. Use four bolts (M16x60) into threaded holes to push the Ring Gear out of carrier, Remove the four bolts (M16x60).

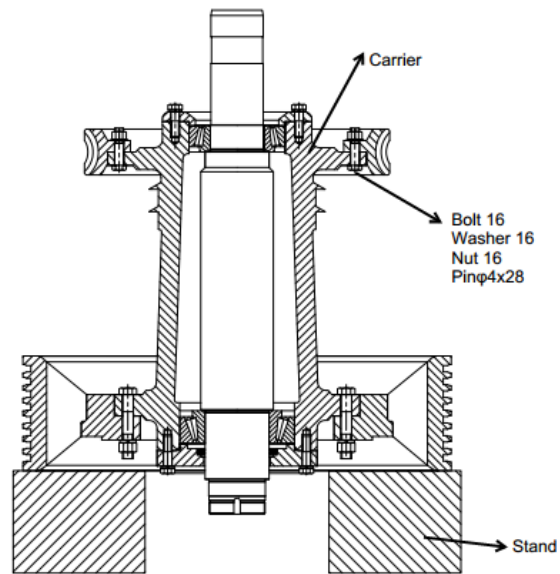

Figure 34 Sheave stands for Ring Gear removal

8.7.2 Ring Gear installation instructions

1. Contact the building engineer to turn off the machine room smoke detectors.
2. Check the mating surface of the new gear and the carrier for any debris that may hinder a flush fit.
3. With a gloved hand, set the new gear (with the mating side down on the carrier), and gently warm the new gear to about 70°C (158°F) and drop onto the carrier.
4. Once the gear is sitting flush, align the holes to match the carrier (drift pins or an existing bolt can be used for alignment).
5. Allow the gear to cool completely, then hand ream the hole from the carrier side up. See Figure 35.

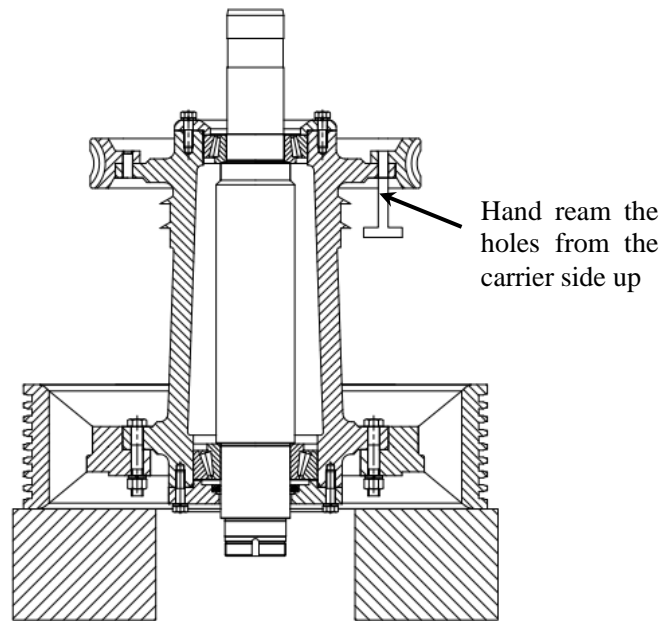

Figure 35 Ring gear replacement

6. Insert and tighten the bolts (M16x1.5x75), nuts (M16x1.5) and lock washer 16 using end wrench (24mm).

NOTE: It may necessary to use the lock nut to pull the bolt through; turn the lock nut until the bolt head is flat on the gear surface. Do not hammer the bolts.

7. Torque the lock nuts to 150Nm (110 ft-lb). Lock them using split (Cotter) pins $\phi 4 \times 28$.
8. Hoist the carrier assembly into the bottom housing.

8.7.3 Backlash Adjustment

1. Reinstall the Pedestal, Round nut, and Shaft seat body.
2. Insert, thread, and tighten the two bolts (M24x120) to 520Nm (371 ft-lb). See Figure 35.



Figure 35 Tighten the two bolts

3. Insert, thread, and tighten the eight bolts (M27x180) to 785Nm (560ft-lb). See Figure 36.

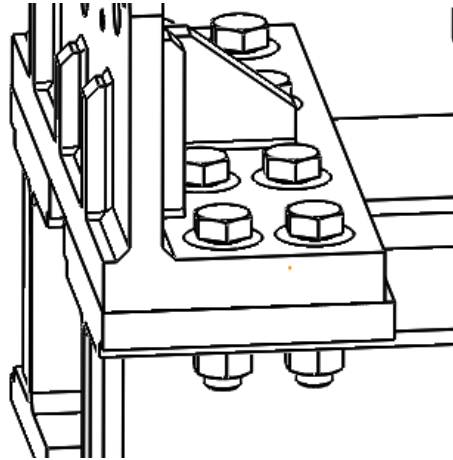

Figure 36 Tighten the eight Pedestal bolts

4. Spray or paint layout color on teeth, rotating the worm shaft in order to drive Ring Gear clockwise and counter clockwise one (1) complete revolution. See Figure 37.
5. Make sure that the Contact Area account for 30% of the gear's width, and for 55% of the gear's height.

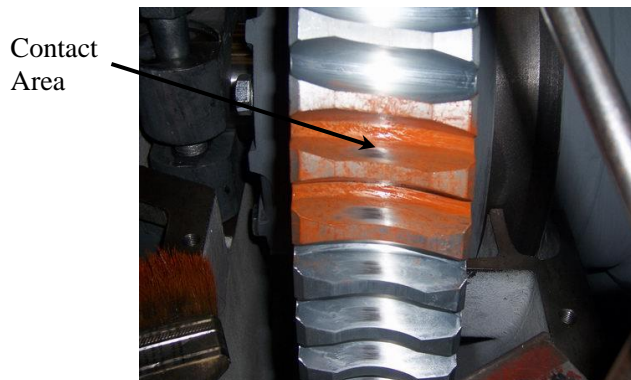

Figure 37 Gear mesh contact check

6. If the Contact Area is to left, loosen the two bolts (M24x180) where the support bodies has the gap place (one on each side of machine); install the bolt (M10) into the pin (A16x60) and pull out the pin; knock the Output shaft from right in order to the Contact Area move right. If the Contact Area is to right use opposite method.
7. Put the magnetic base of the dial indicator on the gear case. See Figure 38.
8. With the dial indicator, Check for backlash between 0.25mm and 0.3mm (0.010-0.012") by rotating the Ring gear (The gap is from the worm with the ring gear out of mesh to the worm with the ring gear in mesh.)
9. Record each measurement of 3 places evenly spaced (120° apart) around the ring gear.

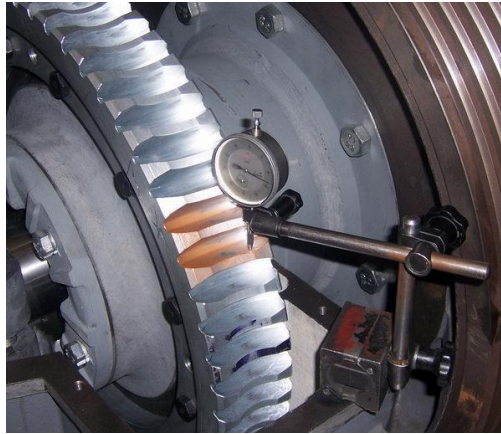

Figure 38 Dial Indicator position

10. If the backlash is not within the range of (0.25mm~0.3mm), loosen the two bolts (M24x180) and the eight bolts (M27x120), then on both sides of the support bodies add or subtract shims.
11. Tighten the two bolts (M24x120) to 520Nm (371 ft-lb) and the eight bolts (M27x120) to 785Nm (560ft-lb). Re-measure the backlash. If it not correct, repeat from step 7.
12. If the relative position of output shaft and support body changed, through the hole in the support body, drill out the pin with a $\Phi 16$ mm drill bit to a depth of 60mm (2.36"); ream the hole with the reamer (16X230).
13. Remove the iron filings from the hole.
14. Knock the pin (A16x60) into the support body.
15. Refer to this manual Sheave Replacement Section 8.6.2 Sheave installation instructions, from step 11 to step 15.
16. Add about 15L (3.9 gallon) elevator gear oil and then secure the top cover with bolt M10x20. **Oil level should be at the red dot of the scale window.**
17. Connect the mainline and test the machine.
18. Reinstall the ropes and remove hoisting and blocking equipment.

8.8 Bearing Replacement



Please refer to the troubleshooting procedure first and make sure that the component is actually bad before performing this replacement procedure.

The bearing replacement work must be done in ground, so the machine must be lifted and moved out of hoist way when perform the bearing replacement work!

Required Tools & Materials:

Hoisting equipment

Bearing heater

Open end wrench: 18mm 24mm

Arm puller

3# General purpose lithium lubricating grease

Bolts (M12x50) (x2)

8.8.1 Output shaft bearing removal

1. Refer to this manual Section 8.7.1 Ring Gear replacement instructions, from step 1 to step 4.
2. Remove the six Bolts (M16x50) and Washers (16) using open end wrench (24mm) then remove the Bearing cover1. See Figure 39.

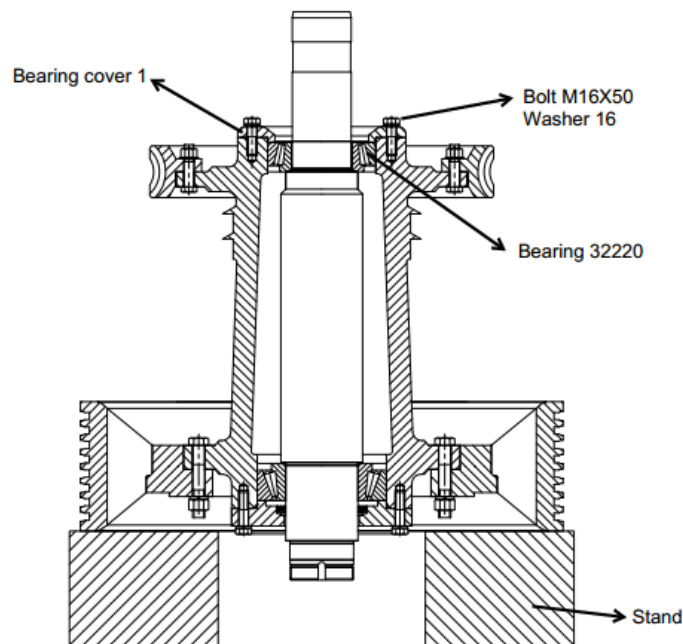

Figure 39 Output Shaft Bearing replacement

3. Turn over the sheave/carrier/ring gear assembly, place two stands under the ring gear surface. See Figure 40.
 4. Remove the six Bolts (M16x60) and Washers (16) using an open end wrench (24mm) then use two bolts (M12x50) into threaded holes to push the Bearing cover2 out, Remove the Bearing cover2 and the two bolts (M12x50).
- NOTE:** When the two bolts (M12x50) contact the carrier, turn each bolt equally in succession to push out the Bearing cover2. **Do not damage the seal.**
5. Install Eye Bolt (M16) into the threaded hole on the output shaft.
 6. Lift the output shaft clear of the drive sheave.

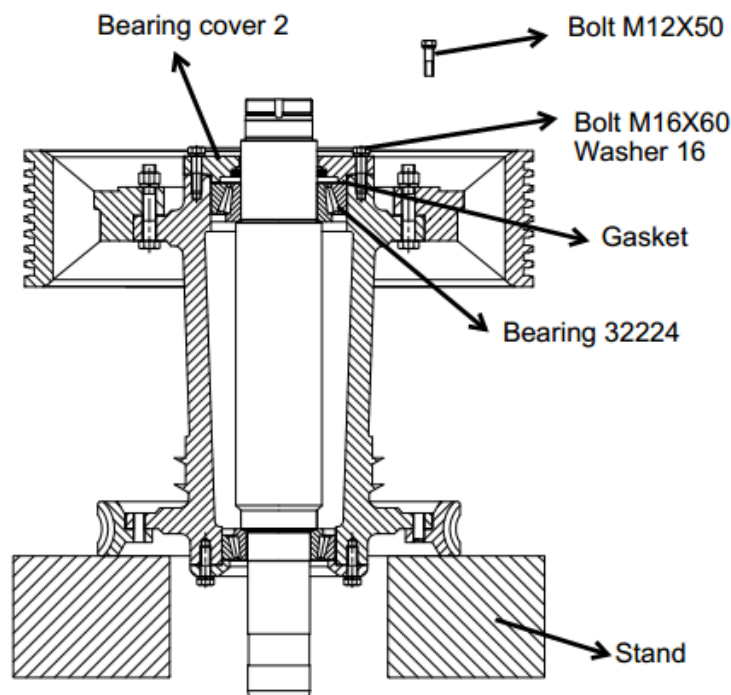

Figure 40 Output Shaft Bearing replacement

7. Move the output shaft onto support stands. See Figure 41.
8. Remove the bearing 32220 with the arm puller. See Figure 42.
9. Remove the bearing 32224 with the arm puller. See Figure 42.

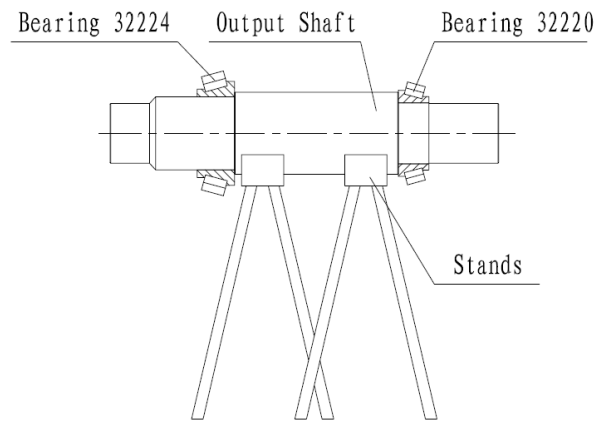

Figure 41 Output Shaft on stands

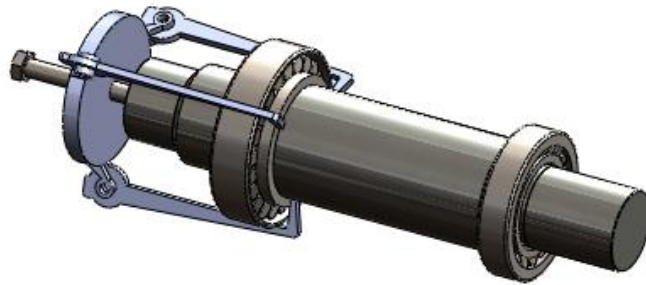

Figure 42 Output Shaft Bearing removal

10. Clean the output shaft's mating surface with the bearing. Make sure there is no rust or greasy dirt.
11. Place the new bearing in or on the bearing heater. And heat it to about $80\pm 15^{\circ}\text{C}$ ($176\pm 59^{\circ}\text{F}$)
12. With a gloved hand, quickly slide the heated bearing fully onto the output shaft.
13. When the bearing has cooled completely, spread 3# General purpose lithium lubricating grease on the inside race of the bearing.
14. Turn the sheave/carrier/ring gear assembly over, place two stands under the sheave surface. See Figure 43.
15. Install the bearing cup 32220 into the bearing bore of the carrier, install the Bearing cover1 then use the six Bolts (M16x50) and Washers (16) to secure it. See Figure 43.
16. Torque the six Bolts (M16x50) to 150Nm (110 ft-lb).

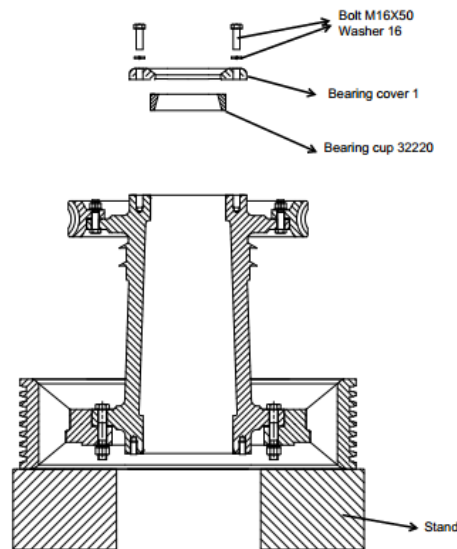

Figure 43 Output Shaft Bearing replacement

17. Turn the assembly over and place two stands under the gear surface. See Figure 44.
18. Install Eye Bolt (M16) into the threaded hole on the output shaft.
19. Lift the output shaft into the carrier. (causing the bearing to seat)
20. Move the Bearing Cup 32224 into the carrier. (causing the bearing to seat) See Figure 41.
21. Put shims on the Bearing then install the Bearing cover2 (including seal and O-ring) and use the six Bolts (M16x60) and Washers (16) to secure it.
22. Check moment of force (10-15Nm, 7.5-11 ft-lb) which causes the output shaft to rotate.
23. Add or subtract shims to get the moment of force in the range 10-15Nm (7.5-11 ft-lb).
24. Torque the six Bolts (M16x60) to 150Nm (110 ft-lb).

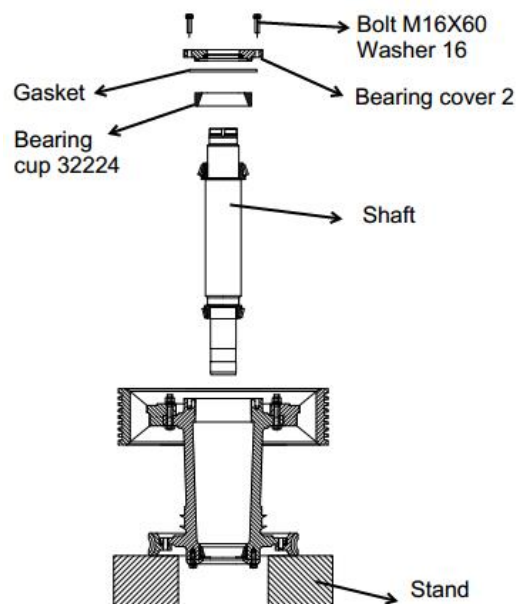

Figure 44 Output Shaft Bearing replacement

25. Hoist the carrier assembly into the bottom gear housing.
26. Refer to this manual Section 8.7.3 Backlash Adjustment, from step 1 to step 18.

8.8.2 Worm Shaft Bearing Replacement

1. Remove the brake system Refer to this manual Section 8.5.1 Brake Lining Replacement Brake removal instructions, Steps 1~2.
2. Remove the Motor Refer to Section 8.3.1, Motor Replacement, Motor removal instructions.
3. Remove the oil drain bolt, drain the oil. Make sure the container can hold more than 15L (3.9 gal).
4. Tighten the oil drain bolt.
5. Remove the Bolt (M12x35) and the washer (12) which secures the worm shaft front cover using the open end wrench (or socket) (18mm), and remove the worm shaft front cover. See Figure 45.
6. Remove the brake drum and put away the key.
7. Remove the six Bolts (M16x50) and the washer (16) which secure the worm shaft through cover using an open end wrench (24mm); remove the worm shaft through cover assembly.
8. Remove the six Bolts (M16x50) and the washer (16) from the worm shaft back cover assembly; remove it.
9. Turn the shaft sheave by hand to remove the worm shaft assembly from the bottom housing.
10. Remove the back load bearing (6312), spacer, and back thrust bearing (51412) using an arm puller as necessary.

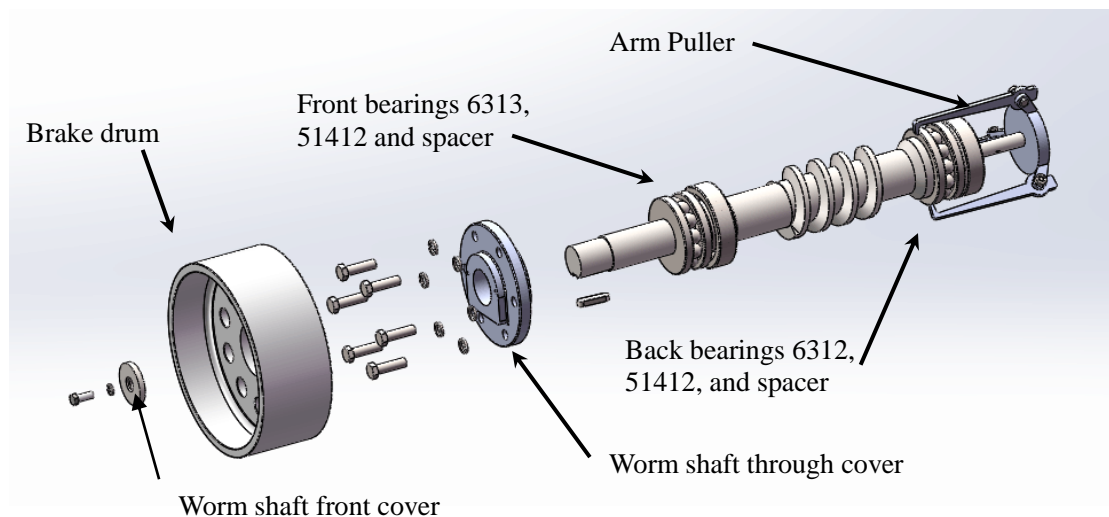

Figure 45 Worm Shaft Bearing replacement

11. Remove the front thrust bearing (51412), spacer, and front load bearing (6313) using an arm puller as necessary.

12. Place the new bearings in the heater and heat them to about $80\pm 15^{\circ}\text{C}$ ($176\pm 59^{\circ}\text{F}$).
13. Quickly slide the heated front load bearing (6313) fully onto the worm shaft. When the bearing has cooled, apply some #3 General Purpose lithium grease in it.
14. Slide the spacer and thrust bearing (51412) onto the shaft. When it has cooled apply grease in it.
15. Turn the shaft sheave by hand to install the worm shaft assembly into the bottom housing.
16. Install the back thrust bearing (51412) onto the worm shaft. When it has cooled apply grease to it. Then add the spacer.
17. Slide the rear load bearing (6312) onto the worm shaft. When it has cooled apply grease to it.
18. Install the worm shaft back cover assembly and some shims into the corresponding hole and screw two bolts (M16x50) and washer 16 opposite each other but do not tighten. See Figure 46.

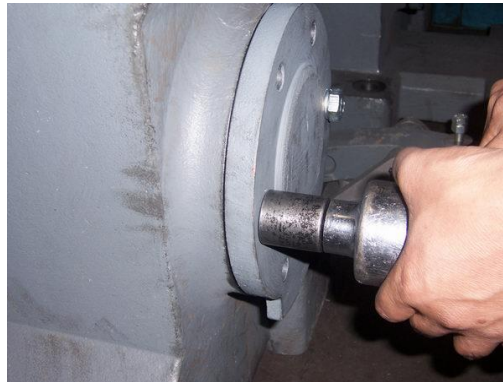

Figure 46 Worm Shaft back cover
Only hand tighten

19. Place the worm shaft through cover into the worm shaft motor side, tighten the worm shaft through-cover with the six Bolts (M16x50) and washers (16) to 150Nm (110 ft-lb) See Figure 47.

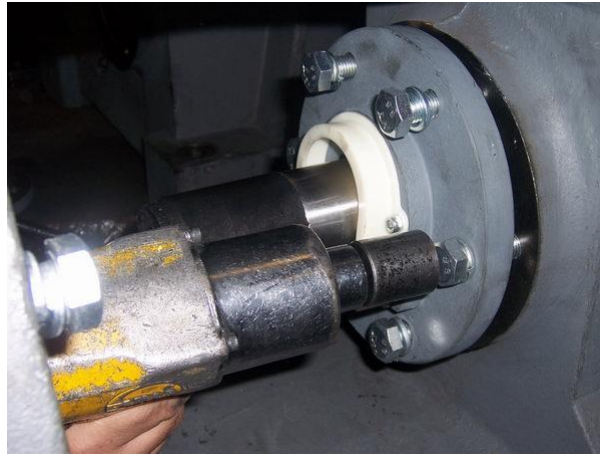

Figure 47 Worm Shaft Bearing replacement

20. Tighten the worm shaft back cover with the Bolts (M16x50) and washers to 150Nm (110 ft-lb).
21. Put the brake drum into the worm shaft, then install the worm shaft front cover assembly, tighten it with bolt (M12x35) and washer (12), and press the brake drum into the position, note the position of the keyway to make the installation of the motor convenient. (The keys of the motor and brake drum must be opposite each other.)
22. Measure the radial travel movement of the brake pulley excircle and the axial gap of the worm shaft with dial indicator. The radial travel movement is no more than 0.1mm, the axial gap is 0.08~0.12mm. Adjust the quantity of the shims until they meet this value. See Figure 48.

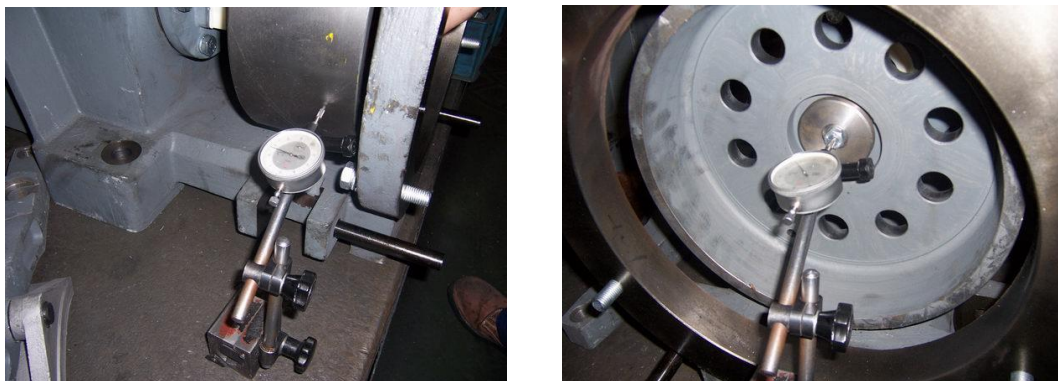

Figure 48 Brake drum radial and axial movement measurement

23. Remove the two bolts (M16x50) and washers (16) then remove the worm shaft back cover, install the O-ring, apply some 3# General purpose lithium lubricating grease. And place the shims to the back bearing bore, tighten it with the six bolts (M16x50) and washers (16) to 150Nm (110 ft-lb).
24. Loosen the bolt M10x20 to turn the Top cover, then add about 15L (3.9 gal) elevator oil.

25. Install the motor Refer to this manual Section 8.3.2, Motor replacement.
26. Reinstall the Brake system. Refer to this manual Section 8.5.2 Brake Lining installation instructions, Steps 5~6.
27. Connect the mainline and test the machine.

8.9 O-Rings and Seal Replacement



Please refer to the troubleshooting procedure first and make sure that the component is actually bad before performing this replacement procedure
If there is oil leakage at a bearing, the O-Rings and Seal must be examined and replacement.

Required Tools & Materials:

Open end wrench: 18mm 24mm

3# General purpose lithium lubricating grease

8.9.1 Output shaft O-ring and seal replacement instructions

8.9.1.1 If the oil leak happened at the bearing cover2 inside:

- a) Refer to this manual Section 8.8.1 Output shaft bearing removal step 1 and step 4 to step 6.
- b) Remove the old seal then apply some 3# General purpose lithium lubricating grease into the new seal (NOK TC $\Phi 120 \times \Phi 150 \times 14$), install it into the bearing cover2. See Figure 49.
- c) Reference to the manual Section 8.8.2 Output shaft bearing installation step 12 to step 17.

8.9.1.2 If the oil leak happened at the bearing cover2 outside:

- d) Refer to this manual Section 8.8.1 Output shaft bearing removal step 1 and step 4 to step 6.
- e) Remove the old O-ring then apply some 3# General purpose lithium lubricating grease into the new O-ring ($\Phi 214.3$ (ID) $\times 5.7$), install it into the bearing cover2.
- f) Reference to the manual Section 8.8.2 Output shaft bearing installation step 12 to step 17.

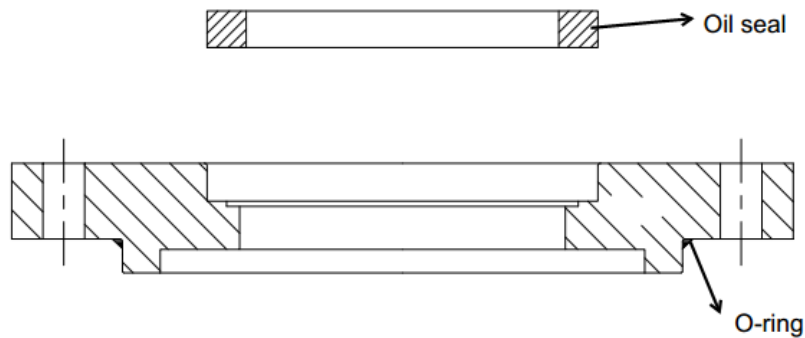

Figure 49 Output shaft seal and O-ring replacement

8.9.2 Worm shaft O-ring and seal replacement

8.9.2.1 If the oil leak happened at the worm shaft back cover:

- Remove the oil drain bolt, drain the oil. Make sure the container can hold at least 15L (3.9 gal). Tighten the oil drain bolt.
- Remove the six bolts (M16x50) and washers (16) then remove the worm shaft back cover and remove the old O-Ring. See Figure 47.
- Apply some 3# General purpose lithium lubricating grease into the new O-Ring ($\Phi 134.4$ (ID) 3.1), and install it onto the worm shaft back cover.
- Tighten the six Bolts (M16x50) and washers (16) to fix the worm shaft back cover to 150 Nm (110 ft-lb).

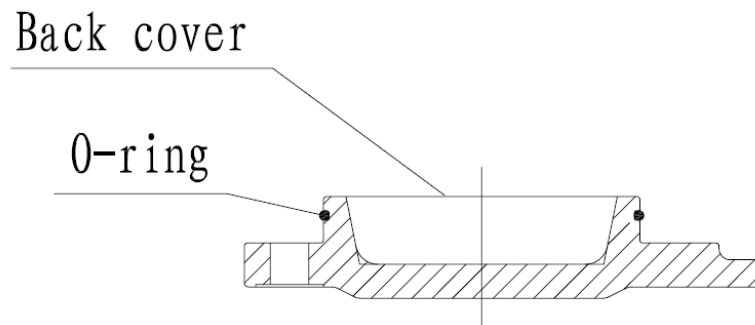

Figure 50 Worm Shaft Back Cover O-ring replacement

8.9.2.2 If the oil leak happened at the worm shaft through cover inside (oil leak is around worm shaft and cover):

- Remove the Through Cover. Refer to this manual Section 8.8.3 Worm shaft bearing replacement Steps 1~7.
- Remove the old seal then apply some 3# General purpose lithium lubricating grease into the new seal (NOK TC $\Phi 60 \times \Phi 80 \times 12$), install it into the through cover. See Figure 51.

- c) Install the Through Cover. Refer to this manual Section 8.8.2 Worm shaft bearing replacement Step 14, step 16 and step 19~21.

8.9.2.3 If the oil leak happened at the worm shaft through cover outside (oil leak is between through cover and lower gear case):

- a) Remove the Through Cover. Refer to this manual Section 8.8.2 Worm shaft bearing replacement Steps 1~7.
- b) Remove the old O-ring then apply some 3# General purpose lithium lubricating grease into the new O-ring ($\Phi 135 \times 3.1$), install it into the bearing cover2.
- c) Install the Through Cover. Refer to this manual Section 8.8.3 Worm shaft bearing replacement Step 14, step 16 and step 19~21.

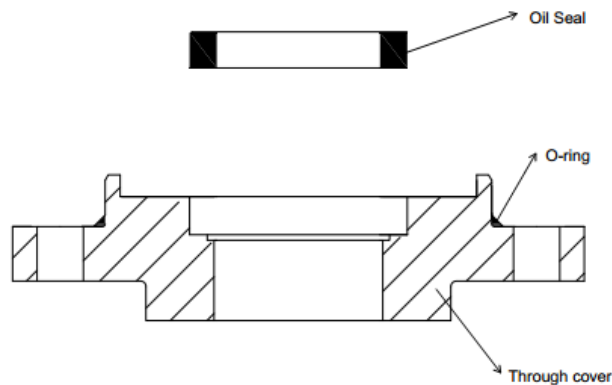

Figure 51 Worm Shaft Through Cover O-ring and seal replacement

9.0 Troubleshooting chart



The proper maintenance of the gear machines requires adequately trained qualified personnel and proper tools.

Faults	Possible causes	Possible solutions
Motor not working	a. Incorrect inverter wiring	Verify the inverter wiring to make sure it is done correctly.
	b. Incorrect inverter parameters	Verify the inverter parameters.
	b. Incorrect encoder wiring	Verify the encoder wiring is correct.
	c. Bad encoder alignment	Verify the inverter alignment procedure is performed correctly.
	d. Loose encoder mounting	Tighten the encoder mounting screws
	e. Bad encoder	Replace the encoder.
	f. Bad brakes	Verify the brake operations
Abnormal noise or vibration	g. Bad motor contactor	Replace motor contactor.
	a. Brake friction noise	a. Verify brake control currents. b. Verify brake strokes.
	b. Bad grounding	Verify that earth ground is good.
	c. Bad inverter parameters	Make sure inverter parameters are correct
	d. Bad encoder feedbacks	Check grounding and shielding.
Electrical shocks	e. Bad bearing	Replace the machine or bearing.
	a. Bad grounding	Make sure that ground is solid.
	b. Bad humidity level	Make sure the humidity is within the specs.
Brake not working	c. Broken cable insulation	Replace the cable.
	a. Oil or grease on brake disk	Remove the oil and change the brake lining.
	b. Incorrect brake stroke	Readjust the brake stroke to factory standard
	c. Brake lining wear out to much	Check the brake lining thickness and readjust the brake stroke or replace the brake
	d. Bad brake coils	Replace the brake assembly
	e. Incorrect counterweight percentage	Verify counterweight percentage
Brake switch Not working	f. Noise absorber height is too big	Reduce the absorber height
	a. Bad wiring	Verify brake wiring
	b. The position of brake switch not installed correctly	Readjust the brake switch position
Motor is too hot	c. Bad brake switch	Replace the switch
	a. Elevator is overloaded	Verify elevator loading and duty cycle
	b. Incorrect counterweight percentage	Verify counterweight percentage

10.0 Traction Machine Assembly

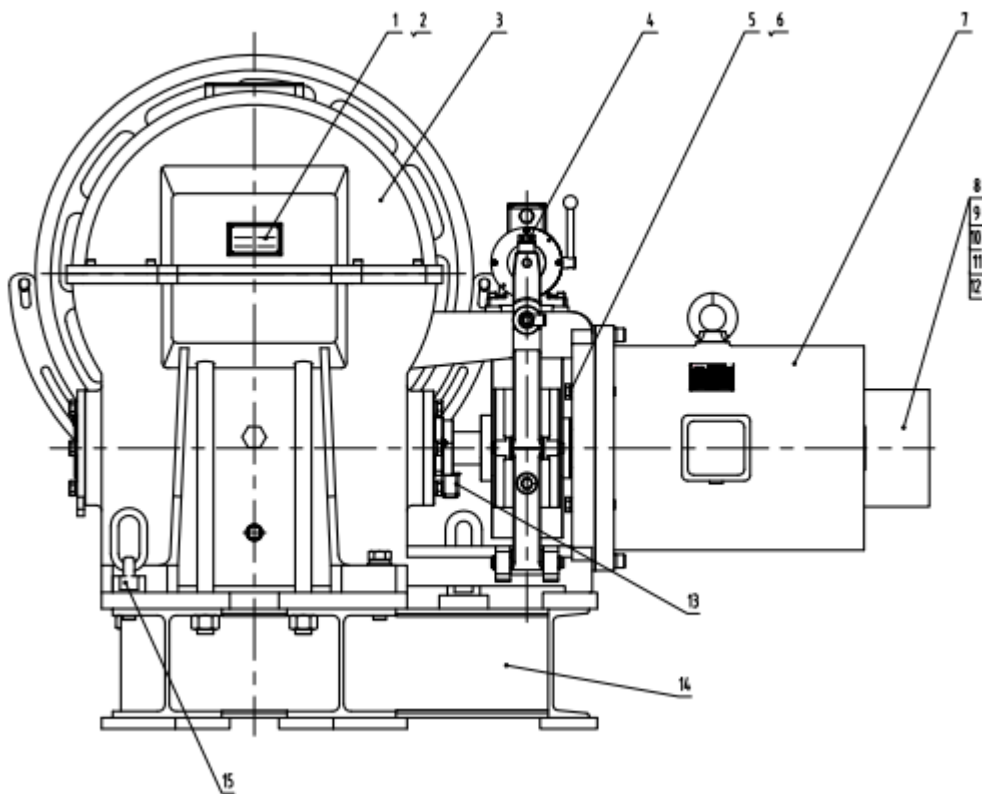

*Indicates Non Stock Item

NO.	Torin Drive Part No.	Description
1	*	Nameplate
2	*	Rivets for nameplate
3	*	Gear box
4	*	Normal Brake
5	*	Bolt M16X75
6	*	Washer 16
7	*	Motor
8	*	Encoder cover
9	*	Screw M8X12
10	*	Washer 8
11	*	Plain washer 8
12	*	Encoder
13	*	Oil collector
14	*	Machine frame
15	*	Lift bolt M16

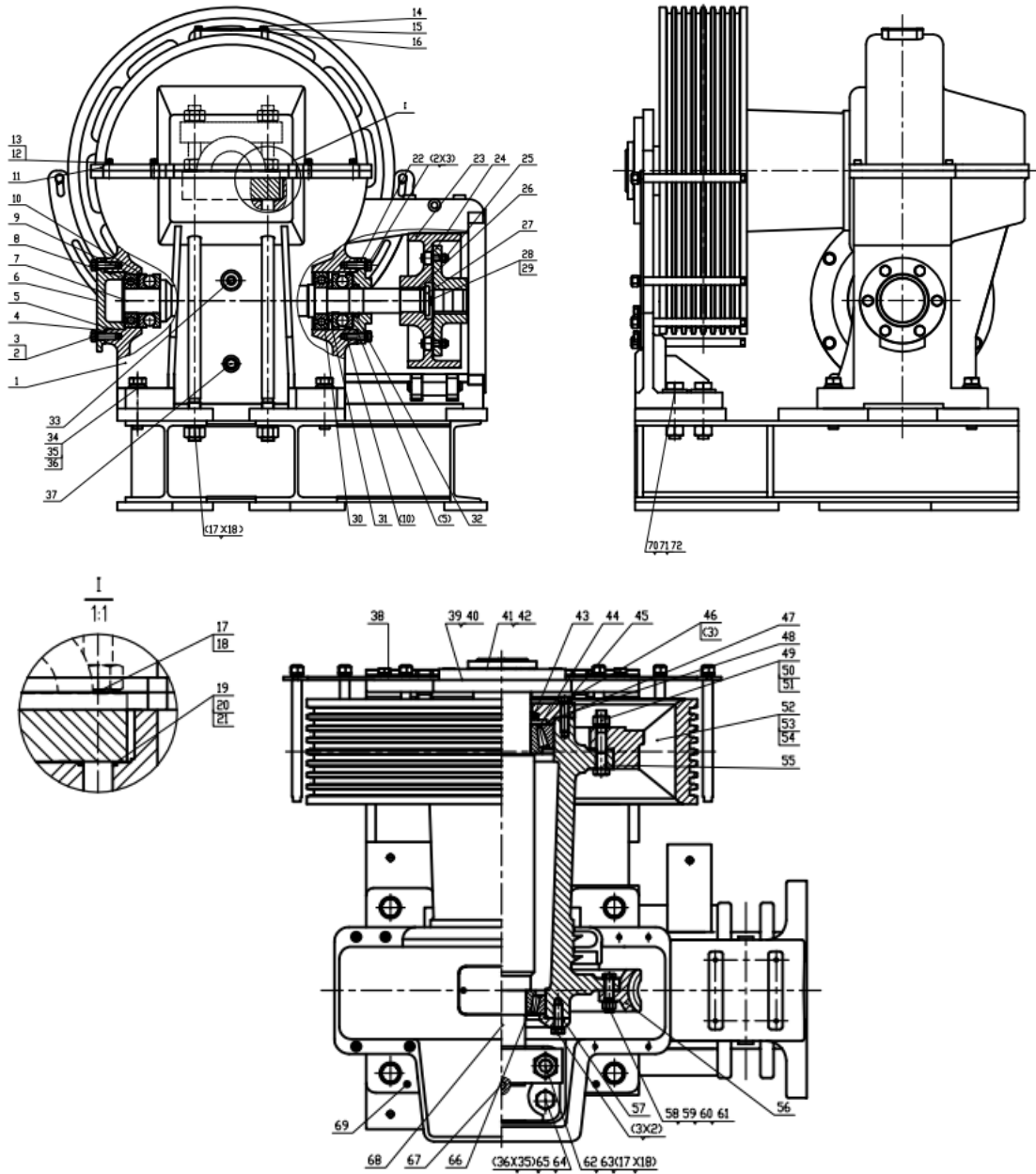

(*) Denotes a non-stock item

NO	Torin Drive Part No.	Description
1	*	Machine body
2	*	Bolt M16X50
3	*	Washer 16
4	*	Packing paper
5	*	NOK O-ring 134.4(ID)X3.1
6	*	Worm rear cover
7	*	Worm
8	*	Bearing NSK 6312
9	*	Bearing spacer A
10	*	Bearing NSK 51412

11	*	Gear case top
12	*	Screw M10X35
13	*	Washer 10
14	*	Bolt M10X20
15	*	Oil top cover
16	*	Gasket for Oil top cover
17	*	Nut M30
18	*	Toothed disc spring washer 30
19	*	O-ring 30(ID)X5
20	*	Gasket A
21	*	Gasket B
22	*	Worm through cover
23	*	Brake drum
24	*	Worm shaft coupling
25	*	Flexible joint
26	*	Key 16X56
27	*	Worm end cover
28	*	Bolt M12X35
29	*	Washer 12
30	*	Bearing NSK 6313
31	*	Bearing spacer B
32	*	NOK Oil seal TC 60 80 12
33	*	Oil level indicator M27X1.5
34	*	Bolt M24X110
35	*	Washer 24
36	*	Special washer for high strength bolt 24
37	*	Oil plug
38	*	Anti-bouncer
39	*	Pedestal
40	*	Gasket for pedestal
41	*	Round nut M105X2
42	*	Tab Washer for round washer 105
43	*	NOK Oil seal TC 120 150 14
44	*	Bearing NSK 32224
45	*	Gasket for shaft
46	*	Bolt M16X60
47	*	NOK O-ring 214.3(ID)X5.7
48	*	Shaft through cover
49	*	Bolt M20X120
50	*	Washer 20
51	*	Nut M20
52	*	Sheave
53	*	Nameplate for sheave
54	*	Rivets for nameplate
55	*	Worm wheel hub
56	*	Worm wheel

57	*	Shaft rear cover
58	*	Nut with fine pitch thread M16X1.5
59	*	Bolt with split pin hole on shank M16X1.5X75
60	*	Split pin ϕ 4X28
61	*	Wave spring cover 16
62	*	Press block for support body
63	*	Threaded rod M30
64	*	Support body
65	*	Bolt M24X120
66	*	Bearing NSK 32220
67	*	Pin A
68	*	Shaft
69	*	Taper pin with internal thread 16x60
70	*	Bolt M27x120
71	*	Dish spring washer 27
72	*	Nut M27

11.0 Induction Motors & Encoders

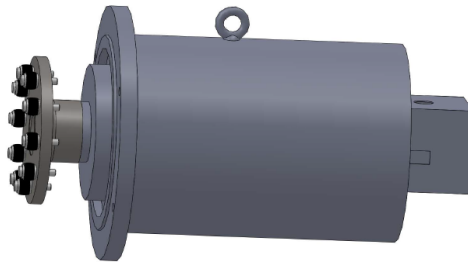

No.	Item	Description
1	PMNC-3545HV	50 HP motor for TGD3B-3545. Coupling installed, 460V
2	PMNC-3550HV	50 HP motor for TGD3B-3550. Coupling installed, 460V
3	PMNC-5020HV	35 HP motor for TGD3B-5020. Coupling installed, 460V
4	PMNC-6020HV	40 HP motor for TGD3B-6020. Coupling installed, 460V
5	PMNC-4535HV	50 HP motor for TGD3B-4535. Coupling installed, 460V
6	PMNC-6035HV	60 HP motor for TGD3B-6035. Coupling installed, 460V
7	PMNC-4540HV	50 HP motor for TGD3B-4540. Coupling installed, 460V
8	PMNC-4545HV	60 HP motor for TGD3B-4545. Coupling installed, 460V
9	PMNC-6045HV	60 HP motor for TGD3B-6045. Coupling installed, 460V
	PMNC-EC001	Elastic coupling insert for TGD1/2/3

No.	Item	Description
1	PEN004	HS35F-100-R2-SS-2048-ABZC-28V/V-TB BEI Encoder
2	PEN004A	HS35R2048H37X36 Dynapar Encoder
3	PEN009	Encoder Cap for TGD1/2/3, with Hardware

12.0 Brake Assembly

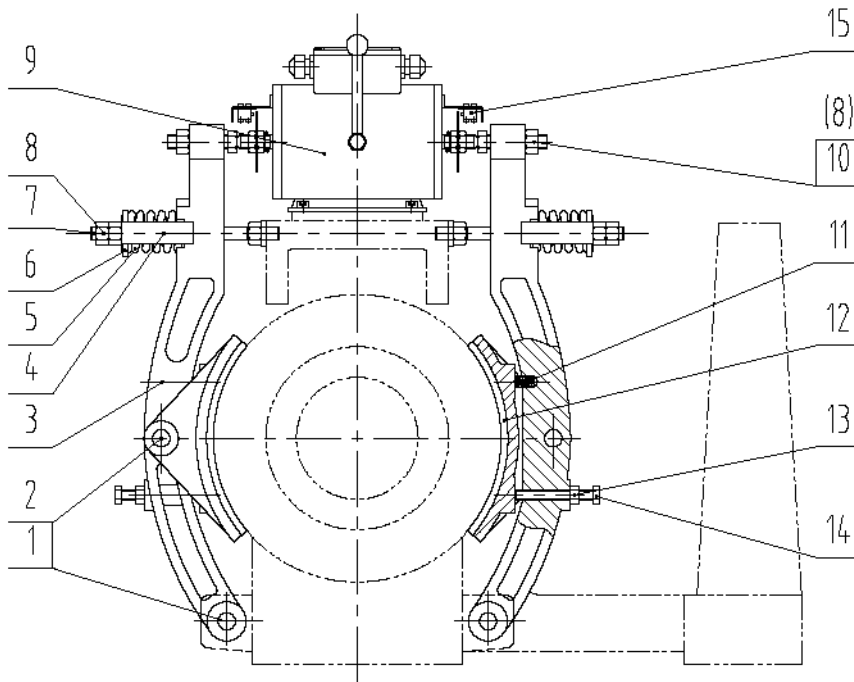

(*) Denotes a non-stock item

NO.	Torin Drive Part No.	Description
1	*	Pin
2	*	Snap Ring 20
3	*	Brake Arm
4	*	Rod
5	*	Brake Spring
6	*	Spring Adjustment Washer
7	*	Spring Bolt
8	*	Nut M16
9	PBK014	Brake Solenoid
10	*	Spacing Bolt
11	PBK034	Bucking (pressure) Spring
12	PBK041	Brake Shoe with lining
13	*	Nut M12
14	*	Bolt M12X90
15	BSW004	Brake Switch

13.0 MECHANICAL DIMENSIONS

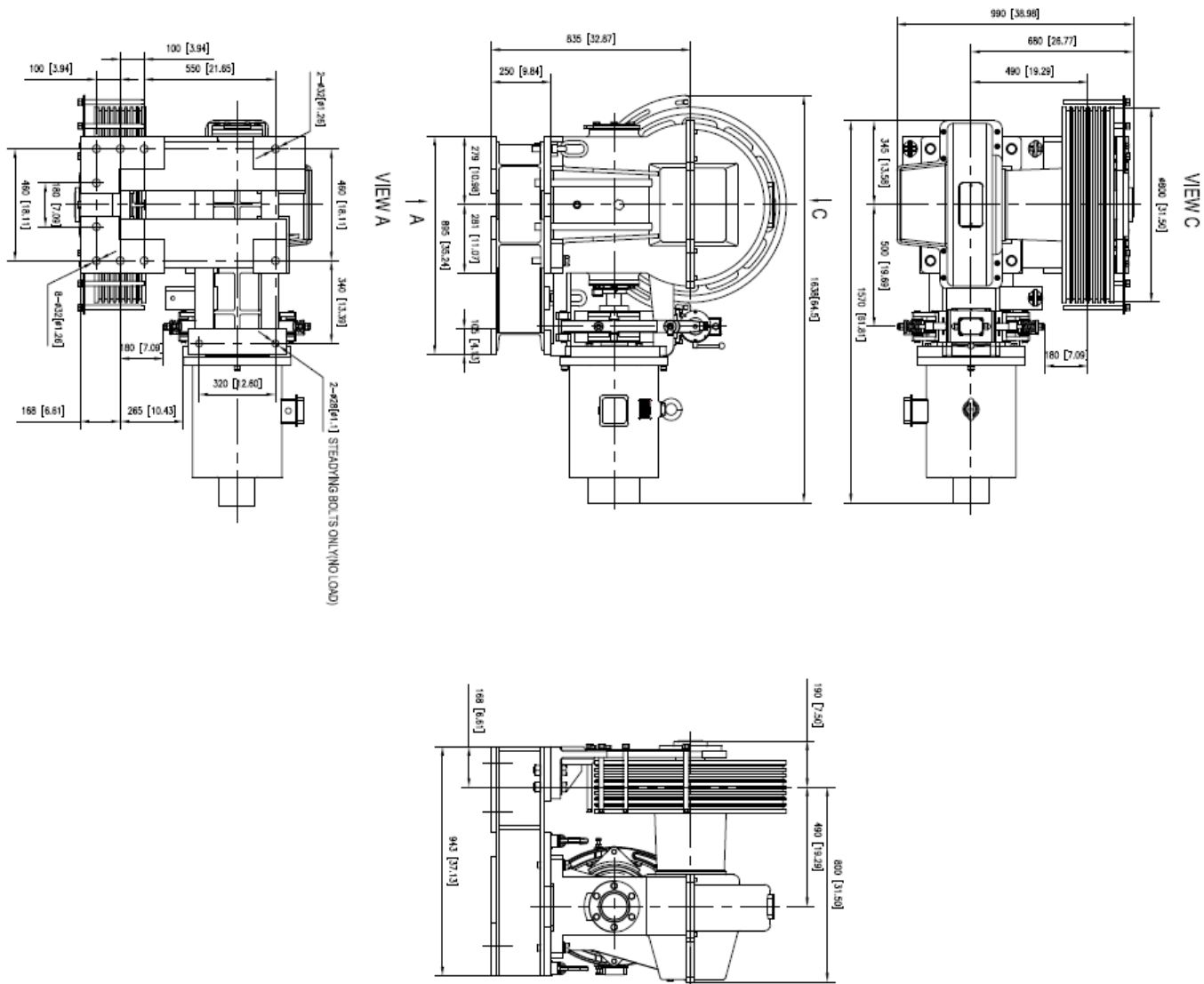

Torin Drive International
 7598 A E Beaty Drive suite 102
 Memphis, TN 38133, USA
 Phone: 901-290-1600
 Fax: 901-290-1680
 E-mail: Info@torindriveintl.com